



V SERIES



VF/VX/ VN/VD

**Bomba centrífuga
vertical multietapa
de acero**

Aplicaciones

Sistemas de refrigeración de agua
Red municipal de abastecimiento y presurización de agua
Red de agua doméstica
Riego
Servicios industriales generales
Plantas de lavado Sistema de alimentación de caldera y condensación
Tratamiento de aguas

Descripción

Bombas centrífugas verticales multietapa de circulación en línea fabricadas en acero inoxidable. Totalmente cerradas, refrigeradas por ventilador, aislamiento clase F, motores IP 55. Motores de una sola fase hasta 2,2 kW.

Certificación WRAS / ACS para agua potable.

Versión VF: parte hidráulica en acero AISI304 SS, aspiración/impulsión bomba en fundición.

Versión VX/VN: toda la bomba disponible en acero AISI304 o AISI316L.

Versión VD: parte hidráulica en AISI904 / SS2205.

Rango de trabajo

Capacidad: Q hasta 240 m³/h

Carga: H hasta 305 m

Temperatura: T hasta 120 °C

Velocidad: n 2900 rpm

Potencia: P hasta 110 kW

Material estándar

Todos los componentes en contacto con el líquido están fabricados en acero inoxidable 304. Se pueden fabricar en acero 316 si se solicita. El cabezal de la bomba y las cámaras de aspiración e impulsión también se pueden fabricar en fundición si se solicita.



Rango de rendimiento

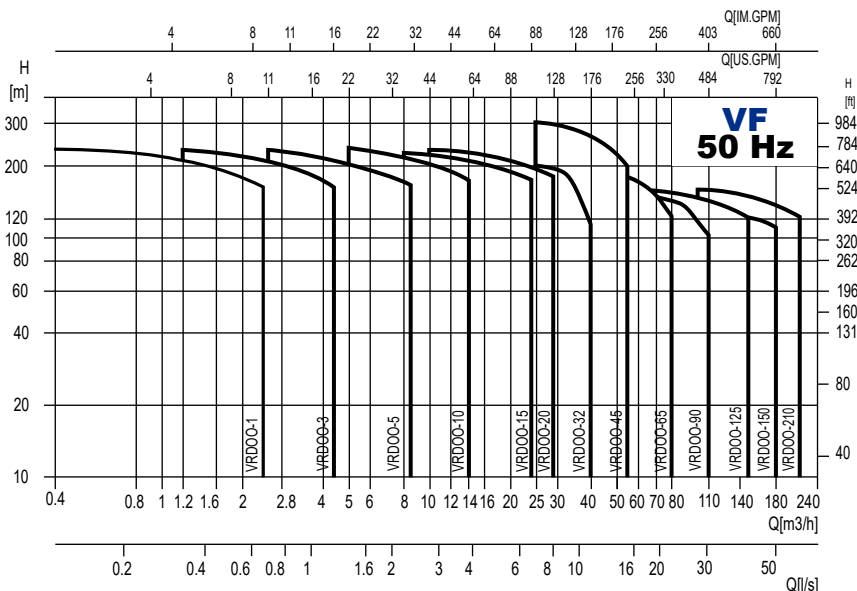

Bomba

Serie V es un tipo de bomba centrífuga vertical multietapa sin auto cebado impulsada por un motor eléctrico estándar.

El eje del motor conecta directamente con el eje de la bomba mediante un acoplamiento. El cilindro resistente a la presión y los componentes de paso de flujo están sujetos dentro del cabezal de la bomba y la cámara de aspiración y de impulsión mediante pernos de fijación.

La entrada y salida están situadas en el fondo de la bomba, en el mismo plano.

Este tipo de bomba se puede equipar con una protección inteligente, para evitar de forma efectiva que funcione en vacío, fuera de fase o con sobrecarga.

Motor

Motor estándar eficiencia IE3 de dos refrigerado por aire según normativa IEC634-2014.

Clasificación protección: IP55

Clasificación aislamiento: F

Tensión estándar: 50HZ:

1x230V

3x230/400V

3x400/690V

Aplicación

Serie V es una especie de producto multifuncional.

Se puede usar para transportar varios medios, desde agua de grifo a líquidos industriales a diferentes temperaturas y con diferentes tasas de flujo y presión.

El tipo VF sirve para líquidos no corrosivos, mientras que el VX, VN es adecuada para líquidos ligeramente corrosivos.

–**Suministro de agua:** Filtrado y transporte de agua en depuradoras y presurización en tuberías principales, presurización en edificios de gran altura.

–**Presurización industrial:** Sistema de procesamiento de agua, sistemas de limpieza, sistemas de lavado a alta presión, sistemas antiincendios.

–**Transporte de líquidos industriales:** Sistemas de refrigeración y de aire acondicionado, calderas de agua caliente y sistemas de condensación, suministro a maquinaria, ácidos y alcalinos.

–**Tratamiento de aguas:** Sistemas de ultra filtrado, sistemas de ósmosis inversa, separadores, piscinas.

–**Riego:** Riego de tierras de cultivo, riego por aspersión, riego por goteo.

Condiciones de funcionamiento

– Líquido fluido, limpio, no inflamable y no explosivo sin contenido de gránulos ni fibras.

– Temperatura del líquido: -15°C +120°C

– Temperatura ambiente: hasta +40°C

– Altitud: hasta 1000m.

Product range

Descripción	VF-1	-3	-5	-10	-15	-20	-32	-45	-65	-90	-125	-150	-210
Tasa de flujo [m3/h]	1	3	5	10	15	20	32	45	65	90	125	150	210
Tasa de flujo [l/s]	0,3	0,8	1,4	2,8	4,2	5,6	8,9	11,7	18	24	33	41,6	55,6
Gama flujo [m3/h]	0,5-2,4	1,2-4,4	2,5-8,5	5-14	8-24	10-29	16-40	25-55	30-80	50-110	60-150	80-180	100-240
Presión máxima [bar]	24	23	24	24	24	23	29	30	22	17	16	16	16
Potencia del motor [kW]	0,37~2,2	0,37~3	0,37~5,5	0,75~11	1,1~15	1,1~18,5	1,5-30	3-45	4-45	5,5-45	11-75	11-75	18,5-110
Temp. [°C]	-15 ~ +120												
Eficiencia máx. [%]	48	58	70	72	73	73	73	75	76	77	74	73	79
Tasas MEI	≥ 0,8			≥ 0,7		≥ 0,7	≥ 0,7	≥ 0,7	≥ 0,6	≥ 0,6	≥ 0,6	≥ 0,6	≥ 0,6
VF	••	••	••	••	••	••	••	••	••	••	••	••	••
VX, VN	••	••	••	••	••	••	••	••	••	••	••	••	••
VD							••	••	••	••	••	••	••
VF, VX, VN, VD Brida DIN	DN25	DN25	DN32	DN40	DN50	DN50	DN65	DN80	DN100	DN100	DN125	DN125	DN150
VX, VN Racor de compresión	DN32	DN32	DN32	DN50	DN50	DN50							
VX, VN Rosca para tubería	R1 1/4	R1 1/4	R1 1/4	R2	R2	R2							
VF, VX, VN Brida ovalada	G1	G1	G1 1/4	G1 1/2									

Definición de modelo

VF, VX, VN 1, 3, 5, 10, 15, 20

VF, VX, VN, VD 32, 45, 65, 90, 125, 150, 210

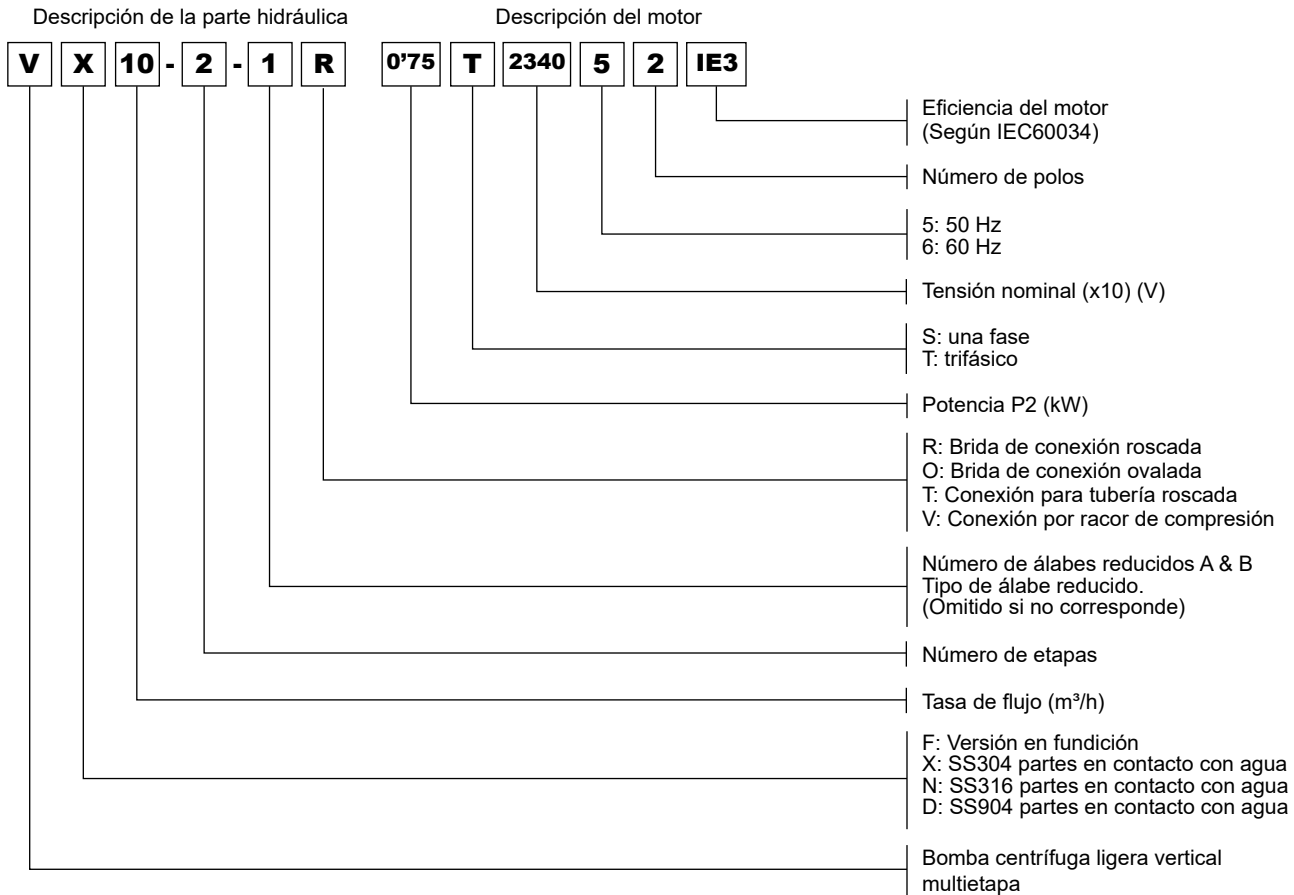

*Para aplicaciones especiales contacte con nuestro equipo de ingeniería de aplicación.

Temperatura ambiente máxima

Cuando la bomba trabaja a temperatura ambiente superior a 40°C o a altitudes superiores a 1000 m, debido a la poca densidad del aire y su poca capacidad de refrigeración, la potencia de salida P2 del motor se ve disminuida hasta cierto punto. Si la bomba funciona en las condiciones descritas anteriormente, se deberá equipar con un motor de mayor potencia.

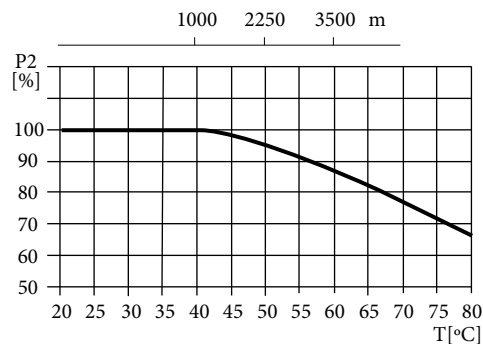

Presión máx. de funcionamiento

Modelo	Presión máxima (bar)
VF, VX, VN 1,3,5,10,15,20 Brida, racor de compresión, rosca para tubería	25
VF, VX, VN 1,3,5,10 Brida ovalada	16
VF 32-10-1 ~ 32-80	16
VF 32-90-2 ~ 32-160	30
VX, VN, VD 32	30
VF 45-10-1 ~ 45-60-2	16
VF 45-60 ~ 45-90	25
VF 45-100-2 ~ 45-130-2	30
VX, VN, VD 45-10-1 ~ 45-90	25
VX, VN, VD 45-100-2 ~ 45-130-2	30
VF 65-10-1 ~ 65-50-2	16
VF 65-50-1 ~ 65-80-1	25
VF 90-10-1 ~ 90-40-2	16
VF 90-40 ~ 90-60	25
VF, VN, VD 65,90	25
VF, VX, VN, VD 125, 150, 210	20

Curva de rendimiento

Las siguientes condiciones son adecuadas para las curvas de rendimiento que se muestran a continuación:

1. Todas las curvas están basadas en un valor medido de 50HZ: velocidad constante del motor 2900rpm ó 2950rpm.

2. La tolerancia de la curva cumple con la norma ISO9906 Anexo A.

3. La medición se realiza a 20°C con agua sin aire, y una viscosidad dinámica de 1 mm²/seg.

4. El funcionamiento de la bomba se refiere al margen de rendimiento indicada por la parte ancha de la curva para evitar sobrecalentamiento por sobrecarga del motor debida a una tasa de flujo demasiado alta.

Imagen de la curva

Etapas

Primer número:

etapas x10

(Excepto para

VDROO1-20)

Segundo número:

Número de álabes

pequeños

La curva de potencia representa la potencia de salida de la etapa, que se divide en tipo de ábabe completo (1/1) y tipo de ábabe pequeño (2/3)

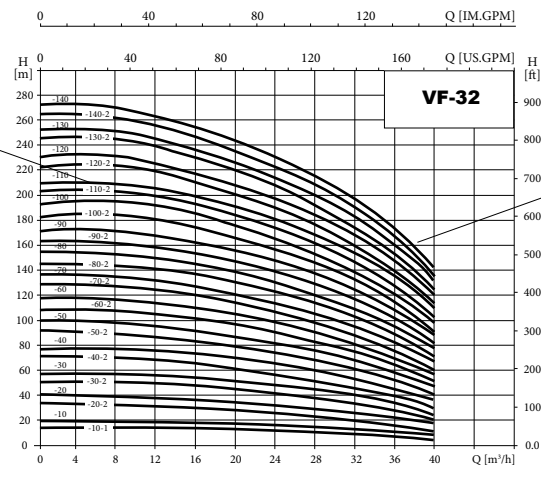

Curva Q-H de la bomba, la línea ancha representa el rango de rendimiento recomendado

La curva Eta representa la eficiencia de la bomba, en el caso de bomba equipada con álabes pequeños. Su eficiencia será 2% menor que la que se muestra en la curva

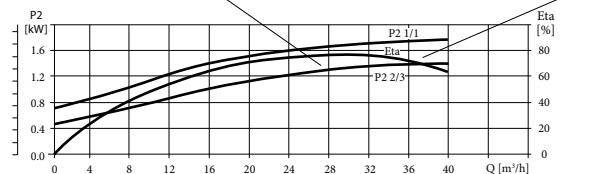

La curva Q-H de cada etapa, con tipo de ábabe completo (1/1) y con el tipo equipado con ábabe pequeño (2/3)

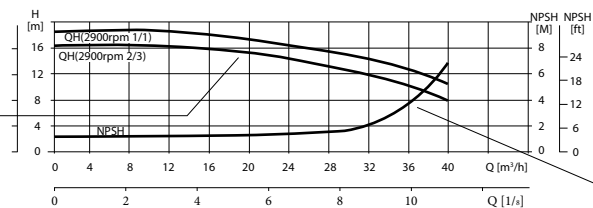

La curva de NPSH representa el valor medio de todas las curvas de esta serie. Se tomará un margen de seguridad de 0.5m al realizar la sección

Presión mínima de entrada NPSH

Cuando la presión dentro de la bomba es menor que la presión del vapor usado para transportar el líquido, se producirá cavitación. Para evitar la cavitación, es necesario garantizar un mínimo de presión a la entrada de la bomba.

La carrera de aspiración máxima se puede calcular mediante la fórmula siguiente:

$P_b \times 10.2 - NPSH - H_f - H_v - H_s$ P_b =presión atmosférica [bar]

(se puede considerar 1 bar)

En un sistema cerrado, P_b indica la presión del sistema [bar]

$NPSH$ =Carga de aspiración positiva neta [m] (Se puede calcular a partir del punto de tasa de flujo máxima posible de la curva de $NPSH$)

H_f =Pérdida de carga de la tubería en la aspiración [m]

H_v =Presión del vapor[m]

H_s =Margen de seguridad=Nivel de carga de impulsión mínima 0,5 m

Si la carga calculada es positiva, la bomba puede funcionar con la carrera de aspiración máxima H.

Si el cálculo de la carga H diera un resultado negativo, será necesario una carga mínima de presión en la aspiración.

Varias bombas conectadas funcionando en paralelo dan más rendimiento que una sola bomba de gran tamaño.

Esto es aplicable a las diferentes etapas de funcionamiento necesarias en un sistema de flujo variable. Se aumenta la posibilidad de suministro de agua cuando falla la bomba, ya que en caso de fallo de la bomba, solo se verá afectada parte del flujo del sistema.

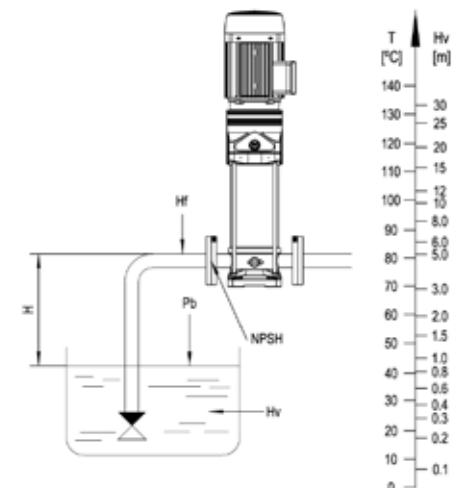
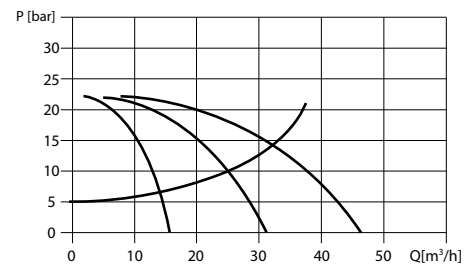

Vista en sección VF, VX, VN 1, 3, 5

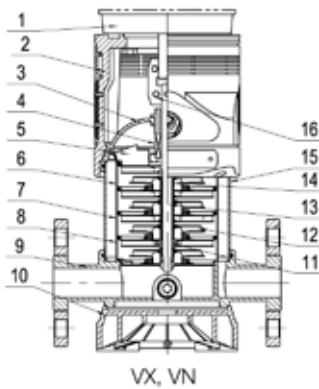
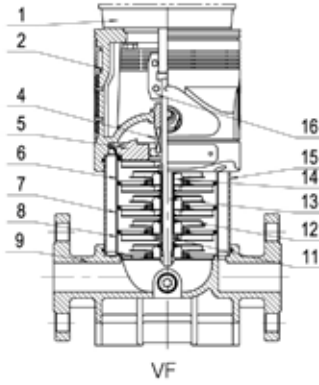

Material VF, VX, VN 1, 3, 5

Nº	Nombre	Material	AISI/ASTM
1	Motor		
2	Cabezal	Hierro forjado	ASTM25B
4	Sello mecánico	SIC/SIC/EPDM	
5	Difusor superior	Acero inoxidable	AISI304 / AISI316L
6	Difusor	Acero inoxidable	AISI304 / AISI316L
7	Difusor de soporte	Acero inoxidable	AISI304 / AISI316L
8	Inductor	Acero inoxidable	AISI304 / AISI316L
11	Rodamiento	Carburo de tungsteno	
12	Rodete	Acero inoxidable	AISI304 / AISI316L
13	Eje	Acero inoxidable	AISI304 / AISI316L
14	Carcasa del rodete	Acero inoxidable	AISI304 / AISI316L
15	Cilindro	Acero inoxidable	AISI304 / AISI316L
16	Unión	Acero al carbono	
VX, VN			
3	Sello base	Acero inoxidable	AISI304 / AISI316L
9	Cámara de aspiración y de impulsión	Acero inoxidable	AISI304 / AISI316L
10	Placa base	Aluminio	ASTM25B
VF			
9	Cámara de aspiración y de impulsión	Hierro forjado	ASTM25B

Vista en sección VF, VX, VN 10, 15, 20

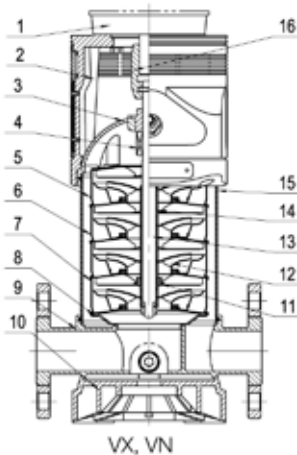
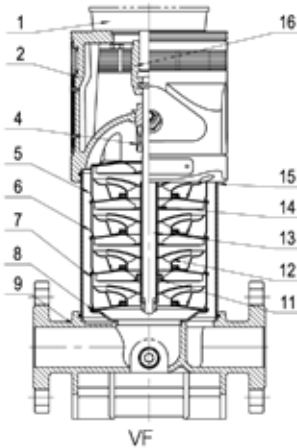

Material VF, VX, VN 10, 15, 20

Nº	Nombre	Material	AISI/ASTM
1	Motor		
2	Cabezal	Hierro forjado	ASTM25B
4	Sello mecánico	SIC/SIC/EPDM	
5	Difusor superior	Acero inoxidable	AISI304 / AISI316L
6	Difusor	Acero inoxidable	AISI304 / AISI316L
7	Difusor de soporte	Acero inoxidable	AISI304 / AISI316L
8	Inductor	Acero inoxidable	AISI304 / AISI316L
11	Rodamiento	Carburo de tungsteno	
12	Rodete	Acero inoxidable	AISI304 / AISI316L
13	Eje	Acero inoxidable	AISI304 / AISI316L
14	Carcasa del rodete	Acero inoxidable	AISI304 / AISI316L
15	Cilindro	Acero inoxidable	AISI304 / AISI316L
16	Unión	Acero al carbono	
VX, VN			
3	Sello base	Acero inoxidable	AISI304 / AISI316L
9	Cámara de aspiración y de impulsión	Acero inoxidable	AISI304 / AISI316L
10	Placa base	Aluminio	ASTM25B
VF			
9	Cámara de aspiración y de impulsión	Hierro forjado	ASTM25B

**Vista en sección
VF, VX, VN, VD 32, 45, 65, 90**

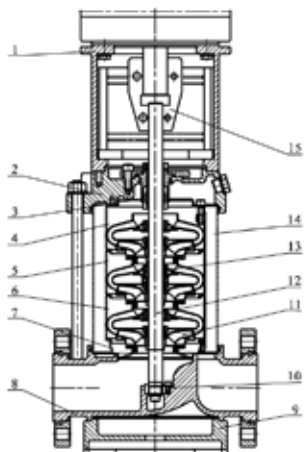

**Material
VF, VX, VN 32, 45, 65, 90**

Nº	Nombre	Material	AISI/ASTM
1	Abrazadera	Hierro forjado	ASTM25B
3	Sello mecánico	SIC/SIC/EPDM	
4	Difusor superior	Acero inoxidable	AISI304 / AISI316 /SS904L
5	Difusor de soporte	Acero inoxidable	AISI304 / AISI316 /SS904L
6	Difusor	Acero inoxidable	AISI304 / AISI316 /SS904L
7	Inductor	Acero inoxidable	AISI304 / AISI316 /SS904L
9	Placa base	Hierro forjado	ASTM25B
10	Rodamiento inferior	Carburo de tungsteno	
11	Rodete	Acero inoxidable	AISI304 / AISI316 /SS904L
12	Eje	Acero inoxidable	AISI304 / AISI316L / AISI431
13	Rodamiento intermedio	Carburo de tungsteno	
14	Cilindro	Acero inoxidable	AISI304 / AISI316 /SS904L
15	Unión	Acero al carbono	
	Partes de goma	NBR	
VF			
2	Cabezal	Hierro forjado	ASTM25B
8	Cámara de aspiración y de impulsión	Hierro forjado	ASTM25B
VX, VN, VD			
2	Cabezal	Acero inoxidable	AISI304 / AISI316 /SS2205
8	Cámara de aspiración y de impulsión	Acero inoxidable	AISI304 / AISI316 /SS2205

**Vista en sección
VF, VX, VN, VD 125, 150, 210**

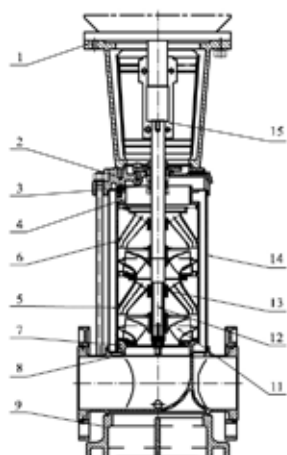

**Material
VF, VX, VN, VD 125, 150, 210**

Nº	Nombre	Material	AISI/ASTM
1	Abrazadera	Hierro forjado	ASTM25B
3	Sello mecánico	SIC/SIC/EPDM	
4	Difusor superior	Acero inoxidable	AISI304 / AISI316 /SS904L
5	Difusor de soporte	Acero inoxidable	AISI304 / AISI316 /SS904L
6	Difusor	Acero inoxidable	AISI304 / AISI316 /SS904L
7	Inductor	Acero inoxidable	AISI304 / AISI316 /SS904L
9	Placa base	Hierro forjado	ASTM 80-55-06
11	Rodete	Acero inoxidable	AISI304 / AISI316 /SS904L
12	Eje	Acero inoxidable	AISI304 / AISI316 /SS904L
13	Rodamiento intermedio	Turgsten carbide	
14	Cilindro	Acero inoxidable	AISI304 / AISI316 /SS904L
15	Unión	Carbon steel	
	Partes de goma	NBR	
VF			
2	Cabezal	Hierro forjado	ASTM 80-55-06
8	Cámara de aspiración y de impulsión	Acero inoxidable	ASTM 80-55-06
VX, VN, VD			
2	Cabezal	Acero inoxidable	AISI304 / AISI316 /SS2205
8	Cámara de aspiración y de impulsión	Acero inoxidable	AISI304 / AISI316 /SS2205

V/F-X-N 1

Vista en sección

Los modelos de etapas 27 a 40 no están disponibles con conexión de brida ovalada.

Las dimensiones exteriores en motor de una sola fase y en motor a prueba de explosiones son un poco diferentes. Contacte con nosotros si necesita más detalles.

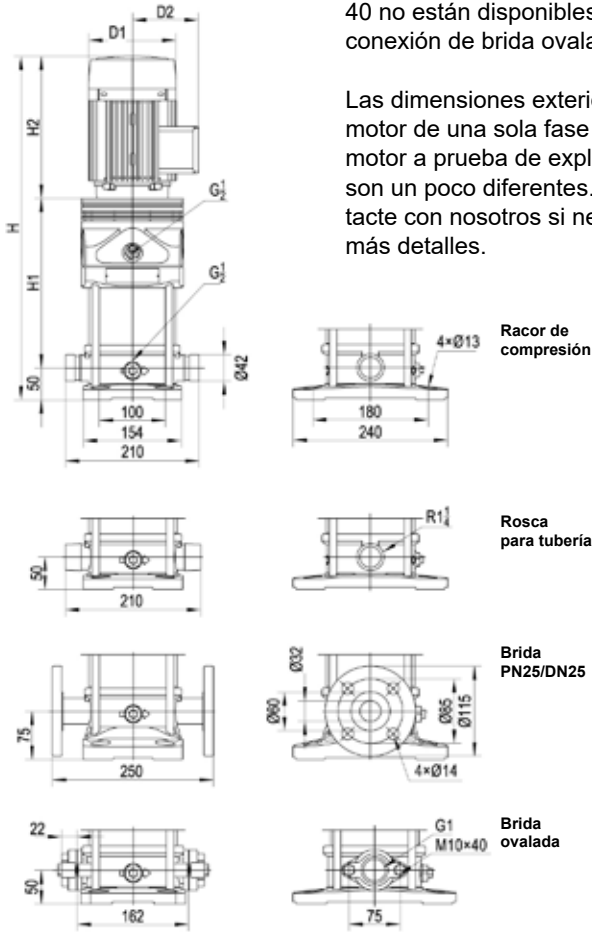

Tamaño y peso

Modelo	Dimensiones de la bomba y el motor					Peso (kg)	
	H1	H2	H	D1	D2	VF	VX, VN
VF, VX, VN-1-3	207	215	497/472	140	103	23	19
VF, VX, VN-1-4	227	215	517/492	140	103	24	20
VF, VX, VN-1-5	247	215	537/512	140	103	24	20
VF, VX, VN-1-6	267	215	557/532	140	103	25	21
VF, VX, VN-1-7	287	215	577/552	140	103	25	21
VF, VX, VN-1-8	307	215	597/572	140	103	27	23
VF, VX, VN-1-9	327	215	617/592	140	103	27	23
VF, VX, VN-1-10	347	215	637/612	140	103	28	24
VF, VX, VN-1-11	367	215	657/632	140	103	28	24
VF, VX, VN-1-12	397	245	717/692	151	108	31	27
VF, VX, VN-1-13	417	245	737/712	151	108	31	27
VF, VX, VN-1-15	457	245	777/752	151	108	32	28
VF, VX, VN-1-17	497	245	817/792	151	108	35	31
VF, VX, VN-1-19	537	245	857/832	151	108	36	32
VF, VX, VN-1-22	597	245	917/892	151	108	37	33
VF, VX, VN-1-25	667	290	1032/1007	171	120	44	40
VF, VX, VN-1-27	707	290	1072/1047	171	120	45	41
VF, VX, VN-1-30	767	290	1132/1107	171	120	46	42
VF, VX, VN-1-32	807	290	1172/1147	171	120	49	45
VF, VX, VN-1-34	847	290	1212/1187	171	120	50	46
VF, VX, VN-1-36	887	290	1252/1227	171	120	51	47
VF, VX, VN-1-38	927	290	1292/1267	171	120	51	47
VF, VX, VN-1-40	967	290	1332/1307	171	120	52	48

Tabla de rendimiento

Modelo	Motor (kW)	Q (m ³ /h)	0	0,5	0,7	1	1,2	1,4	1,6	1,8	2	2,2	2,4
VF, VX, VN-1-3	0,37	H (m)	17,5	17	16,8	16	15,6	14,8	13,5	12	10	8,5	6
VF, VX, VN-1-4	0,37		23,5	23	22,5	21,5	21	19,8	18	16	13,5	11	8
VF, VX, VN-1-5	0,37		29	28,5	28	27	26	24,5	22,5	20	17	14	10
VF, VX, VN-1-6	0,37		35	34,5	34	32,5	31,5	30	27	24	20,5	17	12,5
VF, VX, VN-1-7	0,37		41	40,5	40	39	37	35	32	28	24	20	15
VF, VX, VN-1-8	0,55		47	46	45,5	43,5	42	40	37	33	29	24,5	18
VF, VX, VN-1-9	0,55		52,5	52	51,5	49	47	44,5	41	37	32	27	20,5
VF, VX, VN-1-10	0,55		58,5	58	57	55	52,5	50	46	42	37	31	23
VF, VX, VN-1-11	0,55		64	63,5	63	61	58,5	55	51	46	40	33,5	25,5
VF, VX, VN-1-12	0,75		70	69	68,5	67	64,5	61	57	52	45,5	37	28
VF, VX, VN-1-13	0,75		75,5	75	74,5	73	70	66,5	61,5	56	49	40,5	31
VF, VX, VN-1-15	0,75		87,5	86,5	85,5	84	81	76,5	71	65	57	47	36
VF, VX, VN-1-17	1,1		99	98	97	95	91,5	86,5	81	73	64	53	41
VF, VX, VN-1-19	1,1		110	109	108	106	103	98	91	82	72	59	46
VF, VX, VN-1-22	1,1		128	127	126	122	118	112	105	95	83	69	54
VF, VX, VN-1-25	1,5		146	145	144	139	134	128	121	111	98	83	63
VF, VX, VN-1-27	1,5		158	157	155	150	145	138	130	119	106	90	69
VF, VX, VN-1-30	1,5		175	174	172	167	161	154	145	133	118	100	77
VF, VX, VN-1-32	2,2		189	188	186	180	174	166	155	143	129	110	85
VF, VX, VN-1-34	2,2		200	199	198	192	185	176	165	152	137	117	90
VF, VX, VN-1-36	2,2	212	211	209	203	196	186	175	161	145	124	95	
VF, VX, VN-1-38	2,2	225	224	221	215	208	197	185	171	153	131	101	
VF, VX, VN-1-40	2,2	237	236	233	226	219	208	195	180	161	138	106	

Curva de rendimiento ISO9906:2012 Grado 3B

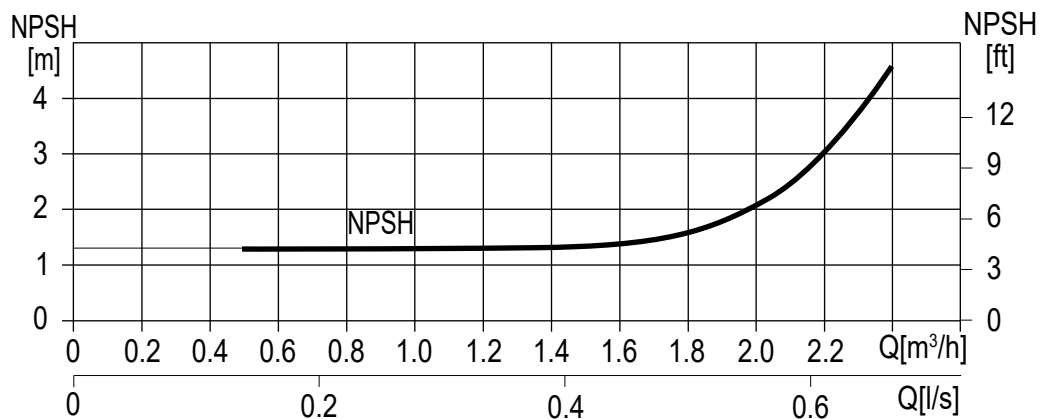
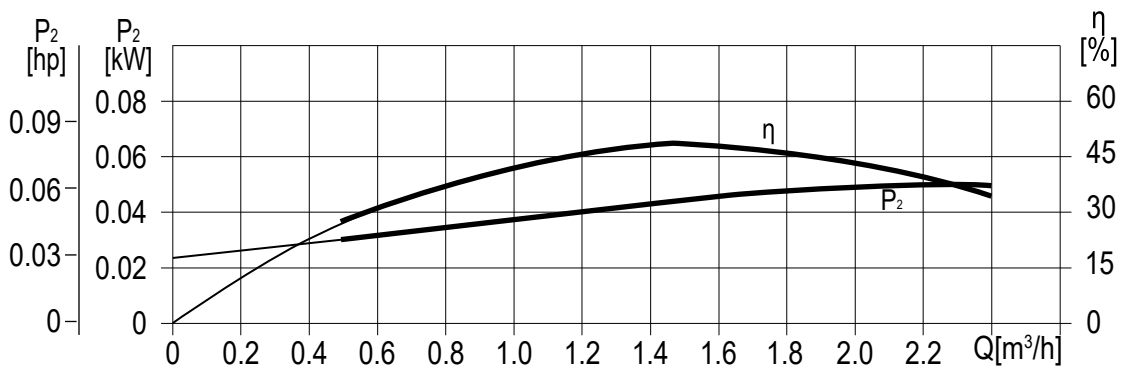
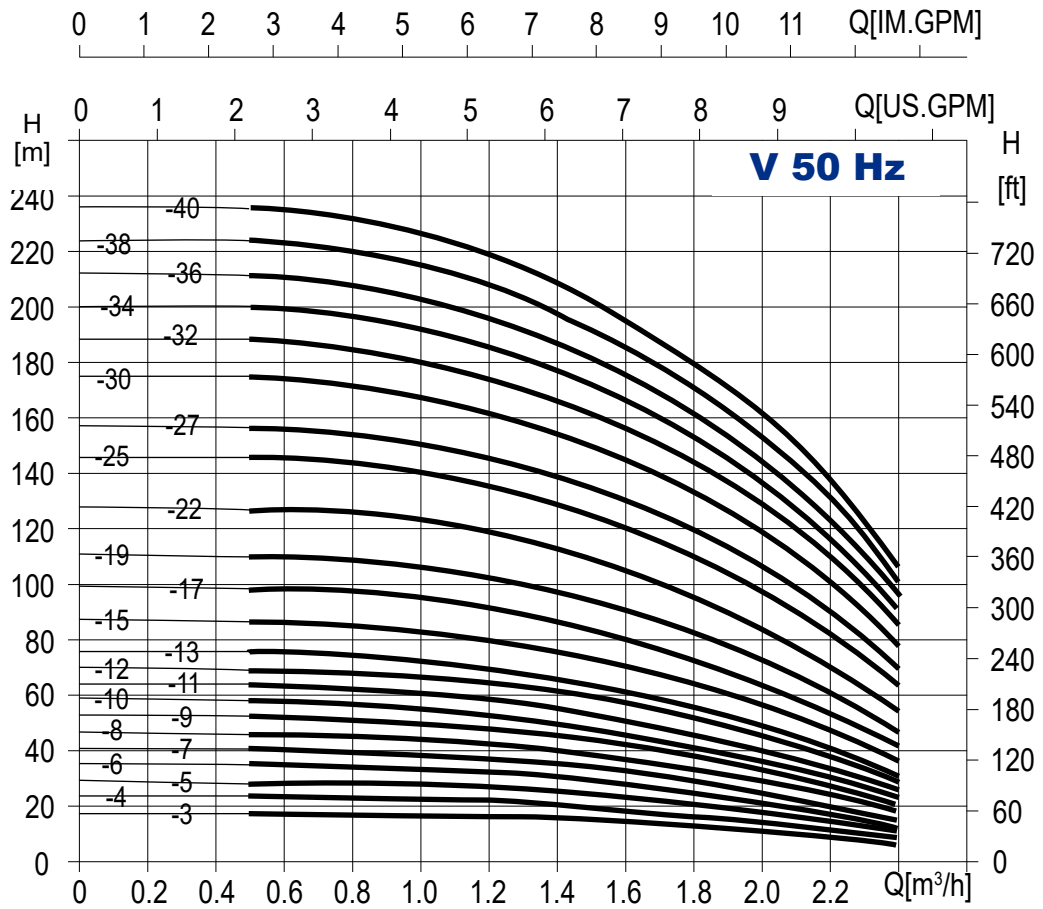

V/F-X-N 3

Esquema de instalación

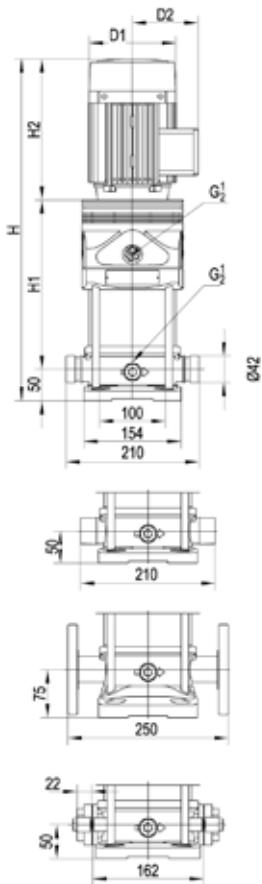

Los modelos de etapas 21 a 31 no están disponibles con conexión de brida ovalada.

Las dimensiones exteriores en motor de una sola fase y en motor a prueba de explosiones son un poco diferentes. Contacte con nosotros si necesita más detalles.

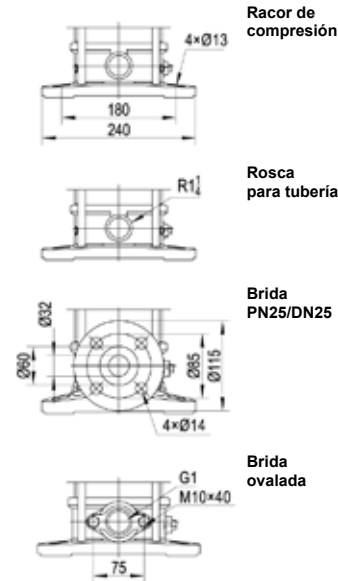

Tamaño y peso

Modelo	Dimensiones de la bomba y el motor					Peso (kg)	
	H1	H2	H	D1	D2	VF	VX, VN
VF, VX, VN-3-3	207	215	497/472	140	103	24	20
VF, VX, VN-3-4	227	215	517/492	140	103	25	21
VF, VX, VN-3-5	247	215	537/512	140	103	26	22
VF, VX, VN-3-6	267	215	557/532	140	103	27	23
VF, VX, VN-3-7	297	245	617/592	151	108	30	26
VF, VX, VN-3-8	317	245	637/612	151	108	30	26
VF, VX, VN-3-9	337	245	657/632	151	108	32	28
VF, VX, VN-3-10	357	245	677/652	151	108	33	29
VF, VX, VN-3-11	377	245	697/672	151	108	33	29
VF, VX, VN-3-12	397	245	717/692	151	108	34	30
VF, VX, VN-3-13	427	290	792/767	171	120	39	35
VF, VX, VN-3-14	447	290	812/787	171	120	40	36
VF, VX, VN-3-15	467	290	832/807	171	120	40	36
VF, VX, VN-3-16	487	290	852/827	171	120	41	37
VF, VX, VN-3-19	547	290	912/887	171	120	44	40
VF, VX, VN-3-21	587	290	952/927	171	120	45	41
VF, VX, VN-3-23	627	290	992/967	171	120	46	42
VF, VX, VN-3-25	677	345	1097/1072	196	132	57	53
VF, VX, VN-3-27	717	345	1137/1112	196	132	58	54
VF, VX, VN-3-29	757	345	1177/1152	196	132	58	54
VF, VX, VN-3-31	797	345	1217/1192	196	132	59	55

Tabla de rendimiento

Modelo	Motor (kW)	Q(m³/h)	0	1,2	1,6	2	2,4	2,8	3	3,2	3,6	4	4,4
VF, VX, VN-3-3	0,37		22,2	21,5	21	20,5	19,5	18	17	16,5	15	12,5	9,5
VF, VX, VN-3-4	0,37		29,7	29	28,5	27,5	26	24	23	22	20	17	13
VF, VX, VN-3-5	0,55		37,2	36	35	33,5	32	30	29	28	25	21	16
VF, VX, VN-3-6	0,55		45	43,5	42,5	41	39	36,5	35	33,5	30	25	19,5
VF, VX, VN-3-7	0,75		52,5	51	50	49	46	43	41	39,5	35	30	23
VF, VX, VN-3-8	0,75		60	58,5	58	56	53	49	47	45	40	34	26,5
VF, VX, VN-3-9	1,1		67,5	66	65	63	60	56	53	51	45	38	30
VF, VX, VN-3-10	1,1		75	73	72	70	66	61	59	56	50	42	33,5
VF, VX, VN-3-11	1,1		82,5	80	79	77	73	68	65	62	55	47	37
VF, VX, VN-3-12	1,1		90	88	86	83	79	74	71	67	59	50	40,5
VF, VX, VN-3-13	1,5		98	95	93	90	86	80	77	73	64	54	44
VF, VX, VN-3-14	1,5		105	102	101	98	92,5	86	83	78	69	58	47
VF, VX, VN-3-15	1,5		113	110	108	105	100	94	90	86	76	64	51
VF, VX, VN-3-16	1,5		120	118	116	112	107	100	96	92	81	69	54
VF, VX, VN-3-19	2,2		143	140	137	132	126	119	114	108	96	82	64
VF, VX, VN-3-21	2,2		158	155	152	147	140	131	126	120	106	90	71
VF, VX, VN-3-23	2,2		173	170	166	161	153	144	138	131	115	97	78
VF, VX, VN-3-25	3		188	185	181	175	166	156	150	142	125	105	85
VF, VX, VN-3-27	3		204	200	195	188	180	169	162	155	138	117	92
VF, VX, VN-3-29	3		220	215	210	203	194	182	175	167	148	126	99
VF, VX, VN-3-31	3		235	230	224	216	207	194	187	178	159	134	106

Curva de rendimiento ISO9906:2012 Grado 3B

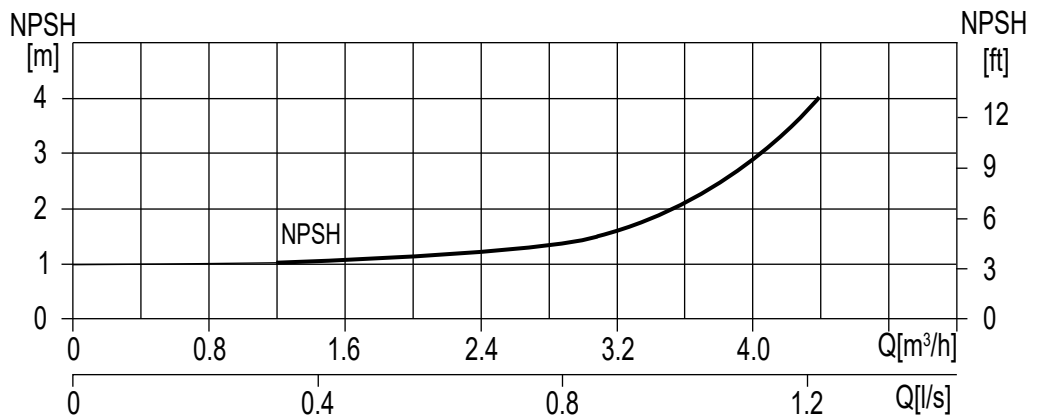
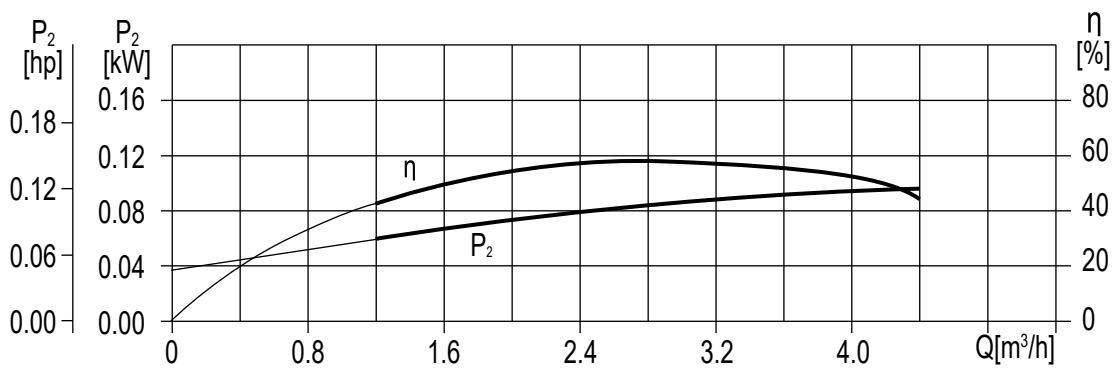
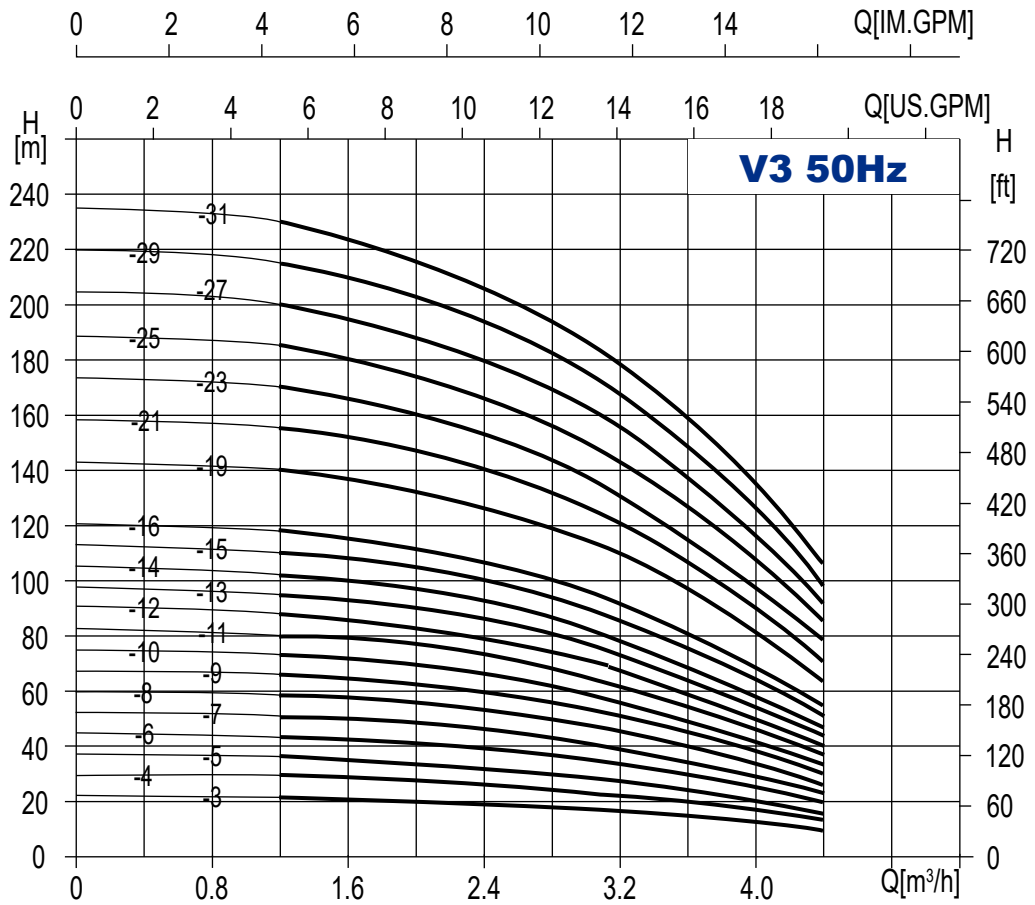

V/F-X-N 5

Esquema de instalación

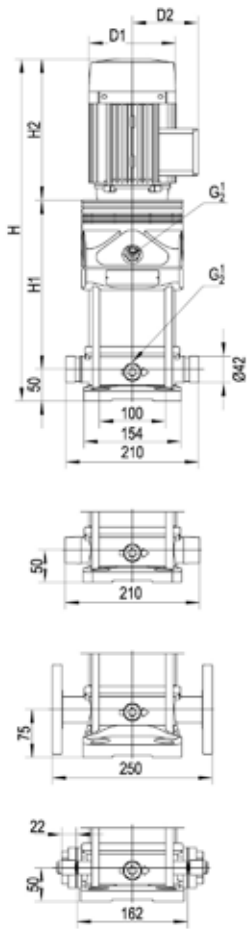

Los modelos de etapas 21 a 31 no están disponibles con conexión de brida ovalada.

Las dimensiones exteriores en motor de una sola fase y en motor a prueba de explosiones son un poco diferentes. Contacte con nosotros si necesita más detalles.

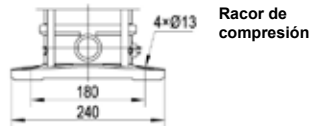

Racor de compresión

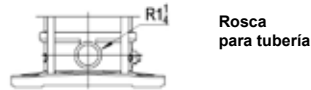

Rosca para tubería

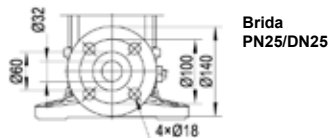

Brida PN25/DN25

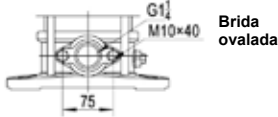

Brida ovalada

Tamaño y peso

Modelo	Dimensiones de la bomba y el motor					Peso (kg)	
	H1	H2	H	D1	D2	VF	VX, VN
VF, VX, VN-5-3	228	215	518/493	140	103	26	21
VF, VX, VN-5-4	255	215	545/520	140	103	27	22
VF, VX, VN-5-5	292	245	612/587	151	108	30	25
VF, VX, VN-5-6	319	245	639/614	151	108	32	27
VF, VX, VN-5-7	346	245	666/641	151	108	32	27
VF, VX, VN-5-8	373	245	693/668	151	108	33	28
VF, VX, VN-5-9	410	290	775/750	171	120	38	33
VF, VX, VN-5-10	437	290	802/777	171	120	39	34
VF, VX, VN-5-11	464	290	829/804	171	120	39	34
VF, VX, VN-5-12	491	290	856/831	171	120	42	37
VF, VX, VN-5-13	518	290	883/858	171	120	42	37
VF, VX, VN-5-14	545	290	910/885	171	120	43	38
VF, VX, VN-5-15	572	290	937/912	171	120	43	38
VF, VX, VN-5-16	599	290	964/939	171	120	44	39
VF, VX, VN-5-18	663	345	1083/1058	196	132	55	50
VF, VX, VN-5-21	744	345	1164/1139	196	132	57	52
VF, VX, VN-5-23	798	355	1228/1203	214	151	65	60
VF, VX, VN-5-25	852	355	1282/1257	214	151	66	61
VF, VX, VN-5-28	933	355	1363/1338	214	151	67	62
VF, VX, VN-5-30	1062	390	1527/1502	257	168	88	83
VF, VX, VN-5-33	1143	390	1608/1583	257	168	89	84

Tabla de rendimiento

Modelo	Motor (kW)	Q(m³/h)	0	2,5	3	4	5	6	7	8	8,5
VF, VX, VN-5-3	0,55		22,1	21	20,5	19	17,5	15	12	9	7,5
VF, VX, VN-5-4	0,55		29,5	28	27,5	26	24	21	17	13	11
VF, VX, VN-5-5	0,75		37	35	34,5	33	30	27	23	18	15
VF, VX, VN-5-6	1,1		44,5	42	41,5	40	37	33	27	21	18
VF, VX, VN-5-7	1,1		52	49,5	48,5	46	42,5	38,5	31,5	24,5	21
VF, VX, VN-5-8	1,1		59	57	56	53	49	44	36	28	24
VF, VX, VN-5-9	1,5		67	64	63	60	55	49,5	41,5	31,5	27
VF, VX, VN-5-10	1,5		74,5	71	70	66	62	55	46	35	30
VF, VX, VN-5-11	1,5		82	78	77	73	68	61	51	39	33
VF, VX, VN-5-12	2,2		89,5	85	84	81	74,5	66	55	43	37
VF, VX, VN-5-13	2,2		97	92	91	87	80	71	60	47	40
VF, VX, VN-5-14	2,2		104	100	98	93	87	77	65	51	43,5
VF, VX, VN-5-15	2,2		112	107	106	100	93	82	69	54	46,5
VF, VX, VN-5-16	2,2		119	114	112	107	99	88	74	58	50
VF, VX, VN-5-18	3		134	128	126	120	111	99	84	66	56
VF, VX, VN-5-21	3		157	150	147	140	130	116	98	77	66
VF, VX, VN-5-23	4		172	165	161	153	142	128	108	86	74
VF, VX, VN-5-25	4		187	179	175	167	155	139	117	93	80
VF, VX, VN-5-28	4		210	201	197	187	174	156	132	105	90
VF, VX, VN-5-30	5,5		225	216	212	201	186	169	144	115	98
VF, VX, VN-5-33	5,5		249	238	234	222	206	187	160	127	109

Curva de rendimiento ISO9906:2012 Grado 3B

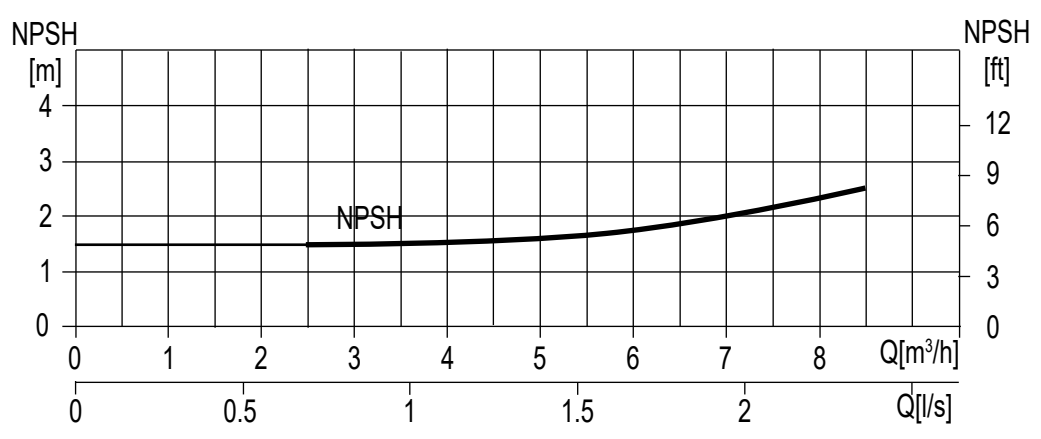
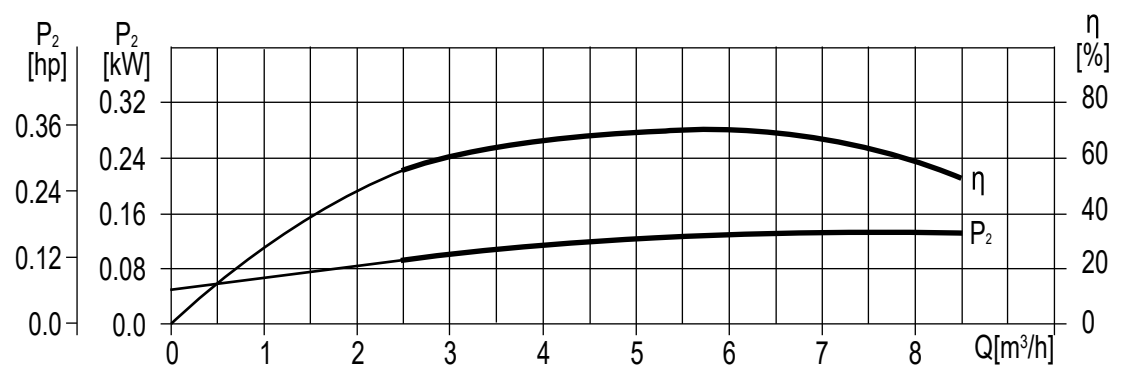
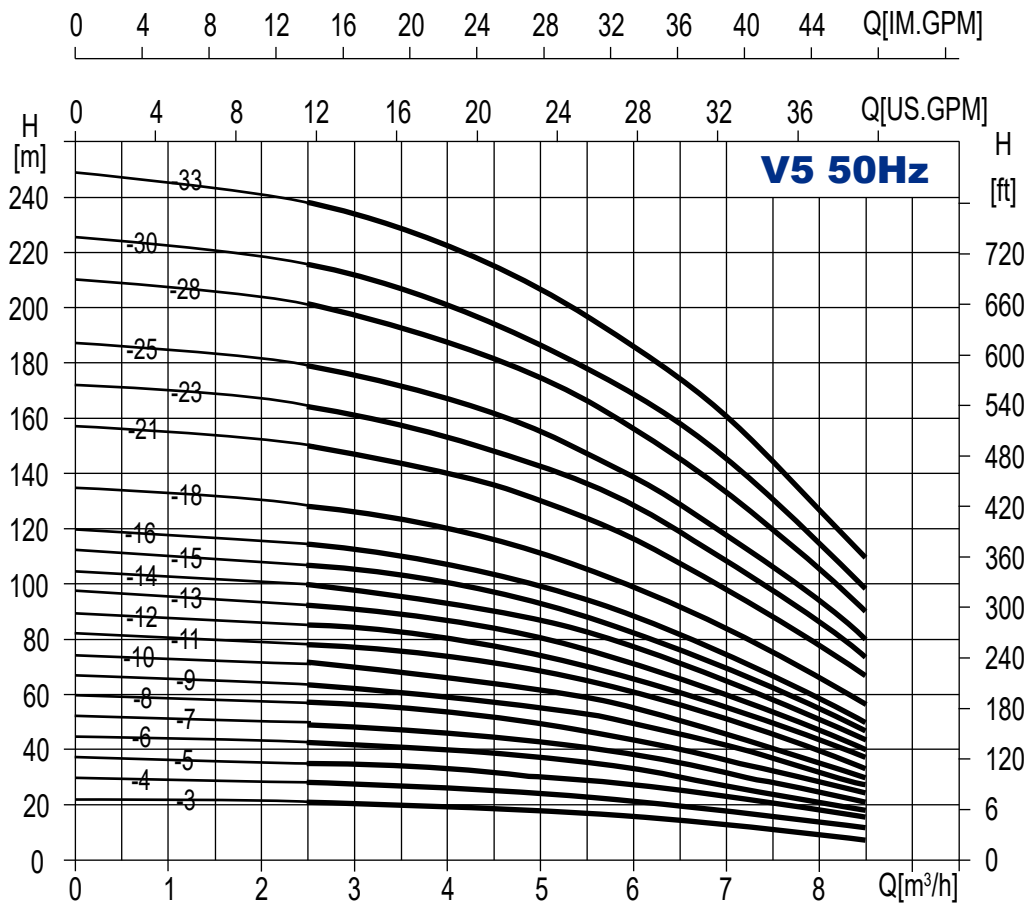

V/F-X-N 10

Esquema de instalación

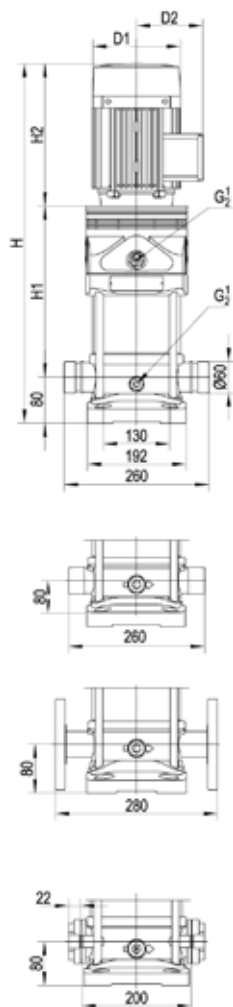

Los modelos de etapas 15 a 22 no están disponibles con conexión de brida ovalada.

Las dimensiones exteriores en motor de una sola fase y en motor a prueba de explosiones son un poco diferentes. Contacte con nosotros si necesita más detalles.

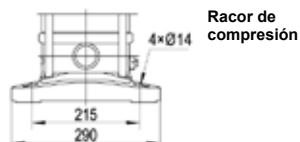

Racor de compresión
4xØ14

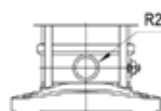
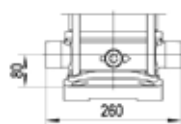

Rosca para tubería
R2

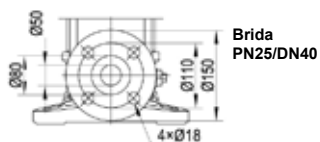
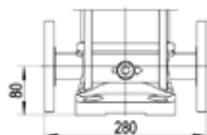

Brida PN25/DN40
Ø80
Ø110
Ø150
4xØ18

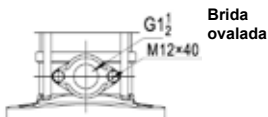
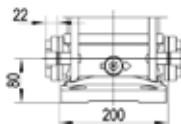

Brida ovalada
G1 1/2
M12x40

Tamaño y peso

Modelo	Dimensiones de la bomba y el motor					Peso (kg)	
	H1	H2	H	D1	D2	VF	VX, VN
VF, VX, VN-10-2	267	245	592	151	108	32	30
VF, VX, VN-10-3	297	245	622	151	108	35	33
VF, VX, VN-10-4	337	290	707	171	120	41	39
VF, VX, VN-10-5	367	290	737	171	120	45	43
VF, VX, VN-10-6	397	290	767	171	120	46	44
VF, VX, VN-10-7	437	345	862	196	132	57	55
VF, VX, VN-10-8	467	345	892	196	132	58	56
VF, VX, VN-10-9	497	355	932	214	151	65	63
VF, VX, VN-10-10	527	355	962	214	151	66	64
VF, VX, VN-10-11	557	355	992	214	151	67	65
VF, VX, VN-10-13	695	390	1165	257	168	88	86
VF, VX, VN-10-15	755	390	1225	257	168	90	88
VF, VX, VN-10-17	815	390	1285	257	168	100	98
VF, VX, VN-10-18	845	390	1315	257	168	101	99
VF, VX, VN-10-20	905	390	1375	257	168	103	101
VF, VX, VN-10-21	935	390	1405	257	168	104	102
VF, VX, VN-10-22	995	500	1575	314	261	170	168

Tabla de rendimiento

Modelo	Motor (kW)	Q(m³/h)	0	5	6	8	10	12	14
VF, VX, VN-10-2	0,75	H (m)	22,2	21	20,5	19	16,5	13,5	9,5
VF, VX, VN-10-3	1,1		33,3	31,5	31	28,5	25,5	22	16,5
VF, VX, VN-10-4	1,5		44,5	42	41	38	34	29	22
VF, VX, VN-10-5	2,2		56	52,5	51	48	43	37	28
VF, VX, VN-10-6	2,2		67	63	62	58	52	44	34
VF, VX, VN-10-7	3		78,5	74	73	69	62	52	40
VF, VX, VN-10-8	3		90	85	84	79	71	60	46
VF, VX, VN-10-9	4		101,5	96	94	89	80	67	52
VF, VX, VN-10-10	4		113	107	105	98	89	76	58
VF, VX, VN-10-11	4		124	118	115	108	98	84	64
VF, VX, VN-10-13	5,5		147	140	138	130	116	99	76
VF, VX, VN-10-15	5,5		171	162	159	149	134	114	88
VF, VX, VN-10-17	7,5		194	184	180	169	153	130	100
VF, VX, VN-10-18	7,5		205	195	191	180	163	141	108
VF, VX, VN-10-20	7,5		228	217	213	200	181	155	120
VF, VX, VN-10-21	7,5		240	228	223	210	191	162	126
VF, VX, VN-10-22	11		250	240	235	221	201	171	132

Curva de rendimiento ISO9906:2012 Grado 3B

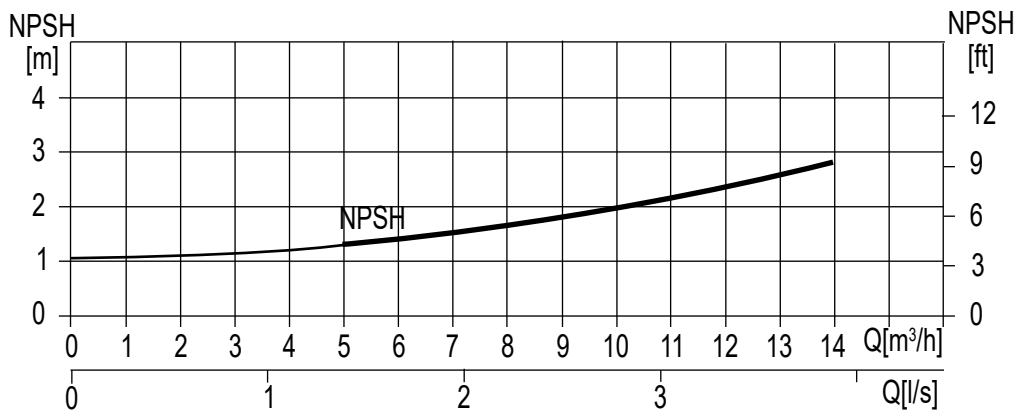
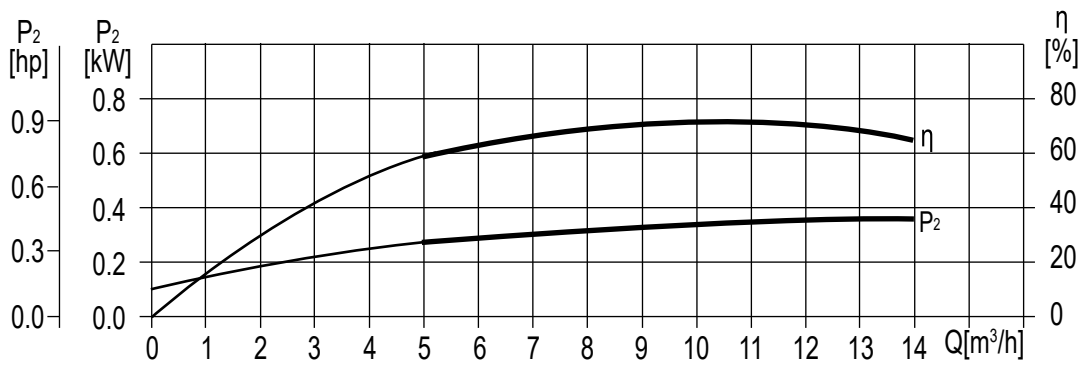
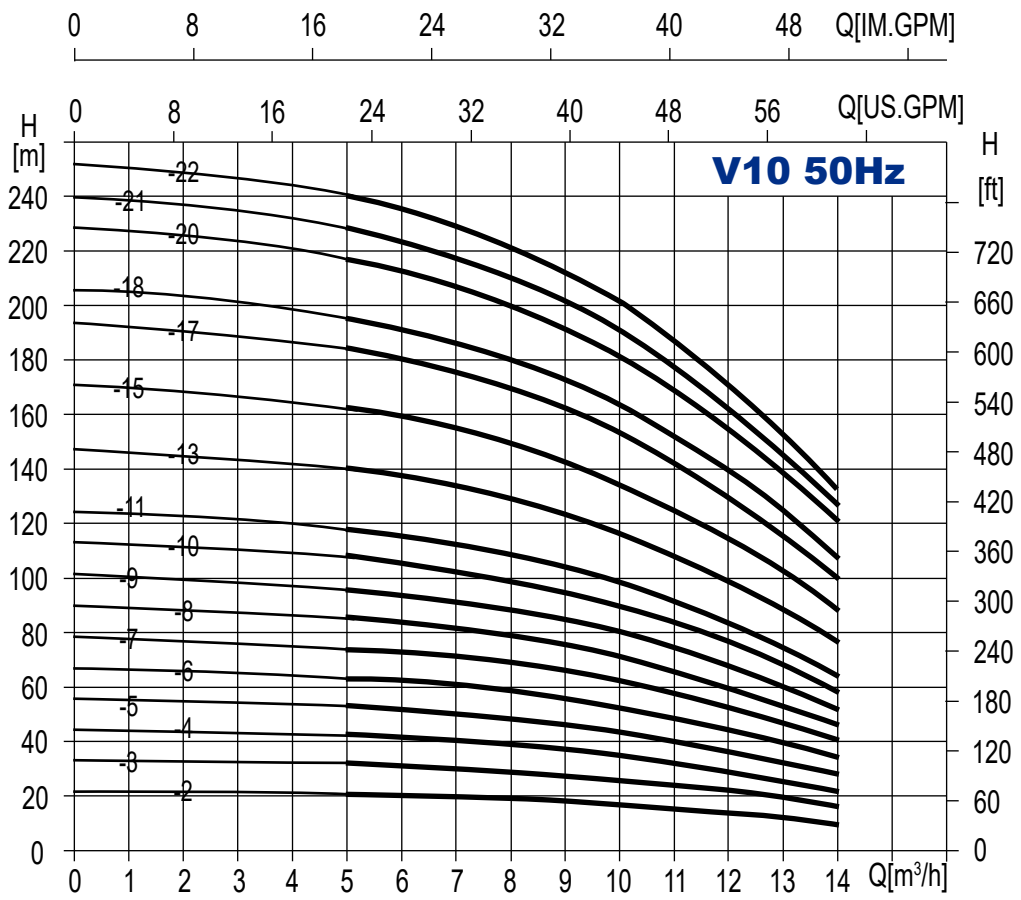

V/F-X-N 15

Esquema de instalación

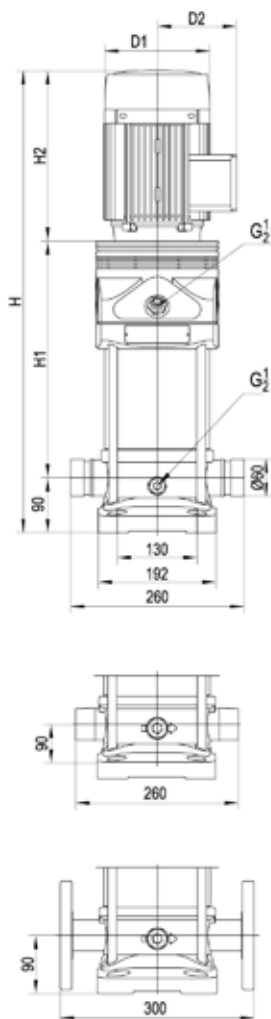

Las dimensiones exteriores en motor de una sola fase y en motor a prueba de explosiones son un poco diferentes. Contacte con nosotros si necesita más detalles.

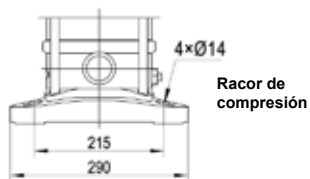

Racor de compresión

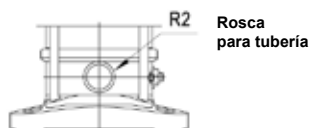

Rosca para tubería

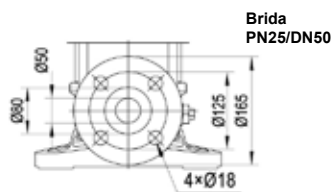

Brida PN25/DN50

Tamaño y peso

Modelo	Dimensiones de la bomba y el motor					Peso (kg)	
	H1	H2	H	D1	D2	VF	VX, VN
VF, VX, VN-15-2	307	290	687	171	120	48	41
VF, VX, VN-15-3	362	345	797	196	132	59	52
VF, VX, VN-15-4	407	355	852	214	151	66	59
VF, VX, VN-15-5	452	355	897	214	151	68	61
VF, VX, VN-15-6	575	390	1055	257	168	90	83
VF, VX, VN-15-7	620	390	1100	257	168	91	84
VF, VX, VN-15-8	665	390	1145	257	168	98	91
VF, VX, VN-15-9	710	390	1190	257	168	99	92
VF, VX, VN-15-10	785	500	175	314	261	157	150
VF, VX, VN-15-12	875	500	1465	314	261	160	153
VF, VX, VN-15-14	965	500	1555	314	261	163	156
VF, VX, VN-15-16	1055	500	1645	314	261	182	175
VF, VX, VN-15-18	1145	500	1735	314	261	184	177

Tabla de rendimiento

Modelo	Motor (kW)	Q(m³/h)	0	8	10	12	14	15	16	18	20	22	24
VF, VX, VN-15-2	2,2	H (m)	26	24,5	24	23,5	23	22,5	21,5	20	18	16	13,5
VF, VX, VN-15-3	3		40	37,5	37	36,5	35,5	34,5	34	32	29	25	21
VF, VX, VN-15-4	4		54	50,5	50	49	47,5	47	46	43	39	34	28,5
VF, VX, VN-15-5	4		68	63	62	61	59	58	57	53	48	42,5	36
VF, VX, VN-15-6	5,5		82	76	75	73	71	69	67	63	58	52	43
VF, VX, VN-15-7	5,5		96	89	88	86	83	81	79	74	68	61	51
VF, VX, VN-15-8	7,5		110	102	100	98	95	93	91	85	78	69	59
VF, VX, VN-15-9	7,5		124	115	113	111	108	106	103	96	88	78	67
VF, VX, VN-15-10	11		138	128	126	124	121	118	115	107	98	87	75
VF, VX, VN-15-12	11		166	154	152	149	145	142	138	129	117	104	90
VF, VX, VN-15-14	11		194	180	177	173	168	165	160	149	136	122	106
VF, VX, VN-15-16	15		222	209	205	200	194	189	184	172	157	142	125
VF, VX, VN-15-18	15		250	235	231	225	218	213	207	194	177	160	141

Curva de rendimiento ISO9906:2012 Grado 3B

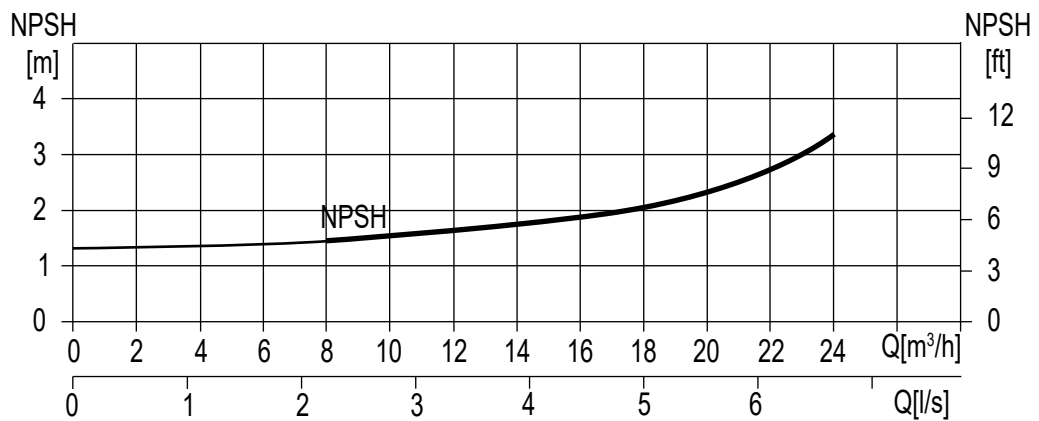
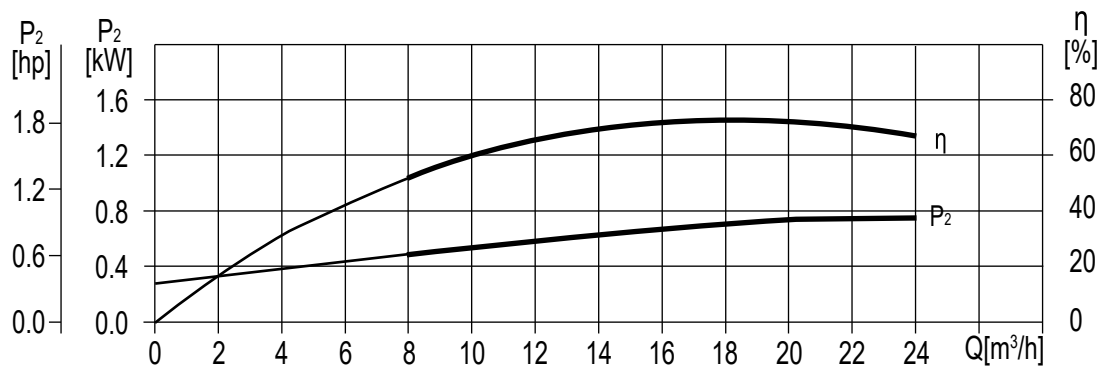
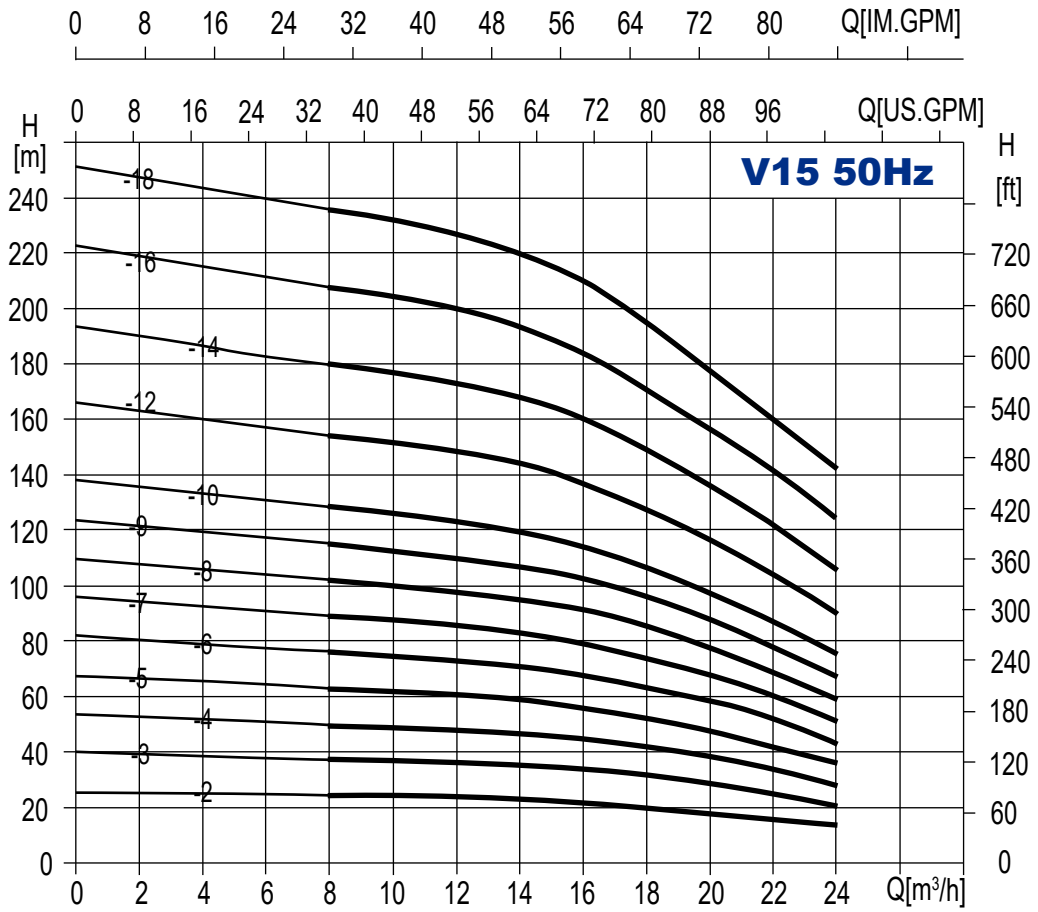

V/F-X-N 20

Esquema de instalación

Las dimensiones exteriores en motor de una sola fase y en motor a prueba de explosiones son un poco diferentes. Contacte con nosotros si necesita más detalles.

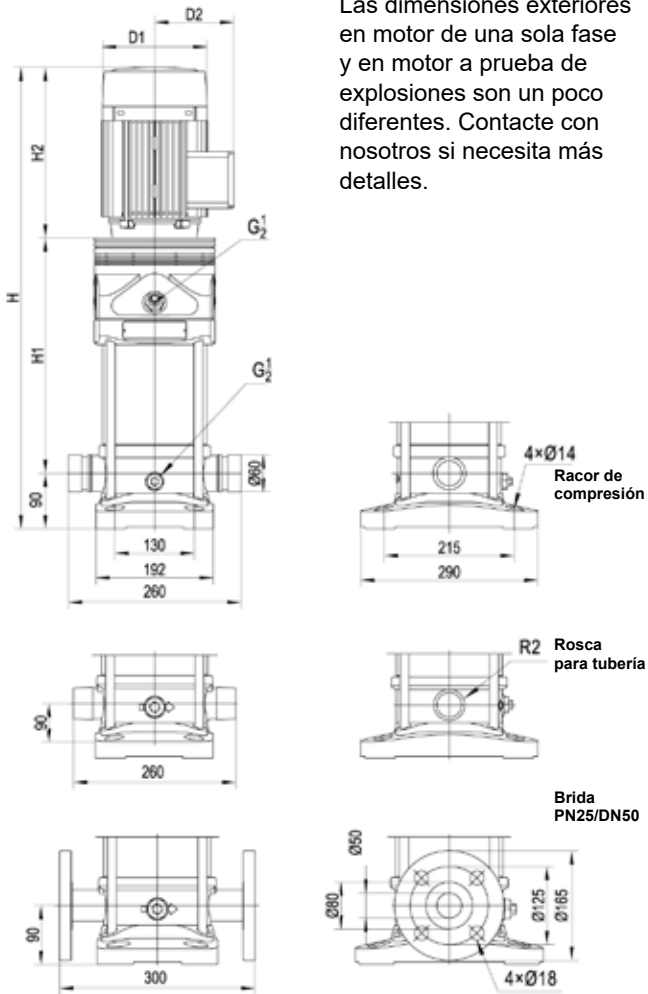

Tamaño y peso

Modelo	Dimensiones de la bomba y el motor					Peso (kg)	
	H1	H2	H	D1	D2	VF	VX, VN
VF, VX, VN-20-2	307	290	687	171	120	48	41
VF, VX, VN-20-3	362	355	807	214	151	66	59
VF, VX, VN-20-4	485	390	965	257	168	88	81
VF, VX, VN-20-5	530	390	1010	257	168	90	83
VF, VX, VN-20-6	575	390	1055	257	168	99	92
VF, VX, VN-20-7	620	390	1100	257	168	100	93
VF, VX, VN-20-8	695	500	1285	314	261	167	160
VF, VX, VN-20-10	785	500	1375	314	261	170	163
VF, VX, VN-20-12	875	500	1465	314	261	188	181
VF, VX, VN-20-14	965	500	1555	314	261	191	184
VF, VX, VN-20-17	1100	550	1740	314	261	212	205

Tabla de rendimiento

Modelo	Motor (kW)	Q(m³/h)	0	10	12	14	16	18	20	22	24	26	28	29
VF, VX, VN-20-2	2,2		27,2	25,5	25	24,5	24	23,7	23	22	20,5	18	16	14,5
VF, VX, VN-20-3	4		41,5	39,5	39	38	37	36	35	33	31	28	25	23,5
VF, VX, VN-20-4	5,5		55,5	52,5	51	50	49	48,5	47	45	41,5	37	33	31,5
VF, VX, VN-20-5	5,5		69,5	66	65	64	62	60	58	55	51	47	42	40
VF, VX, VN-20-6	7,5		84	79	78	77	75	73	70	66	62	58	52	48
VF, VX, VN-20-7	7,5		98	92,5	91	90	88	85	82	78	73	68	61	57,5
VF, VX, VN-20-8	11		113	106	105	103	101	98	95	90	84	77	70	66
VF, VX, VN-20-10	11		141	133	132	130	127	123	119	113	106	97	88	83
VF, VX, VN-20-12	15		171	160	158	156	153	149	143	137	127	117	106	100
VF, VX, VN-20-14	15		200	187	185	183	179	174	168	160	149	137	124	117
VF, VX, VN-20-17	18,5		244	228	225	222	218	212	205	195	182	168	154	147

Curva de rendimiento ISO9906:2012 Grado 3B

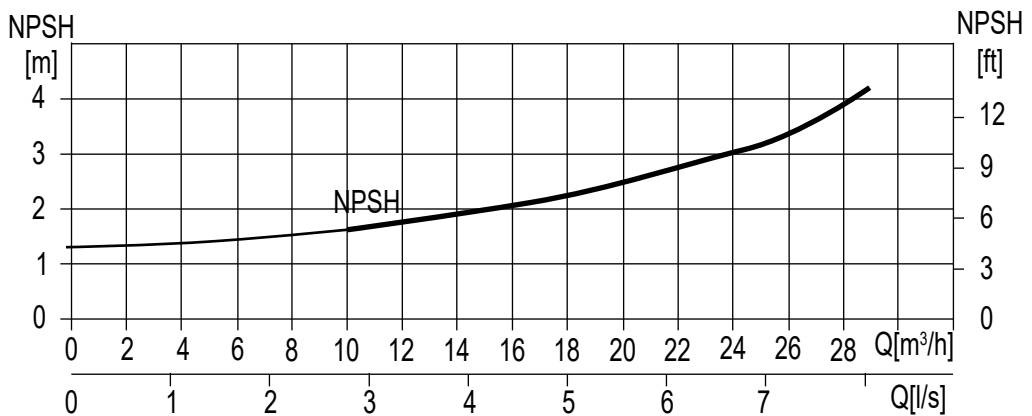
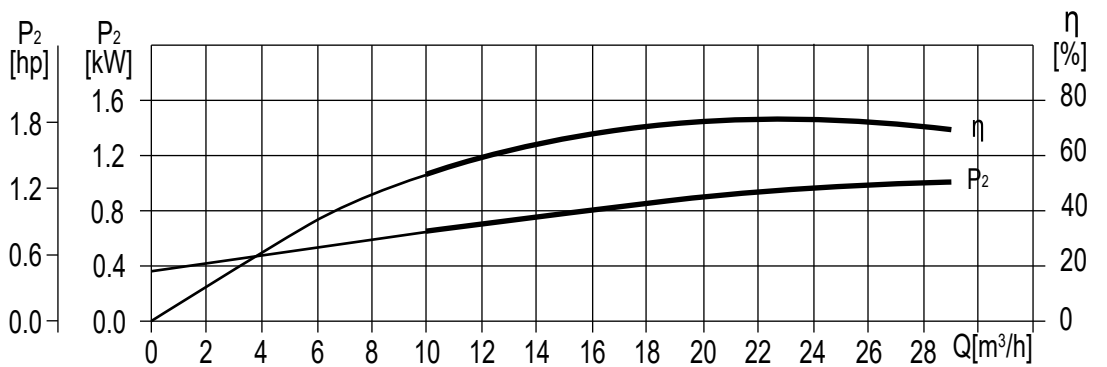
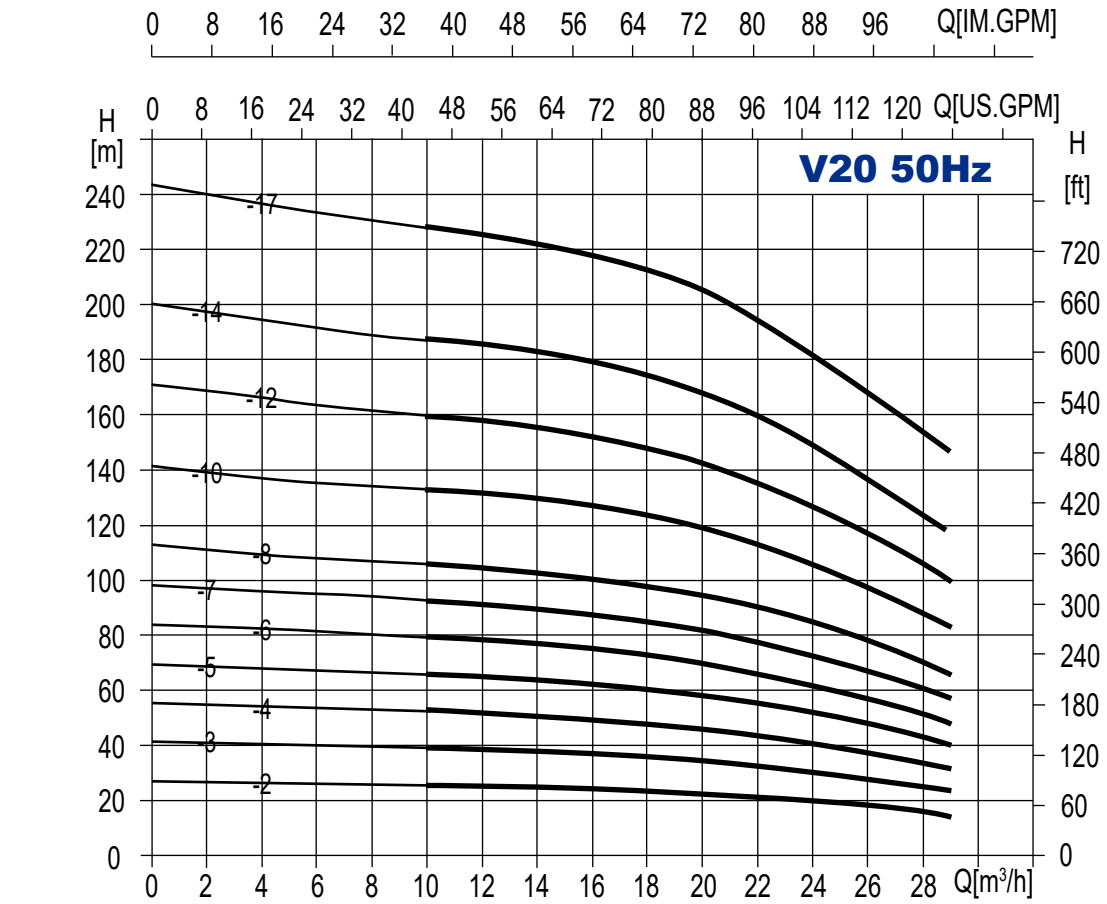

V/F-X-N-D 32

Esquema de instalación

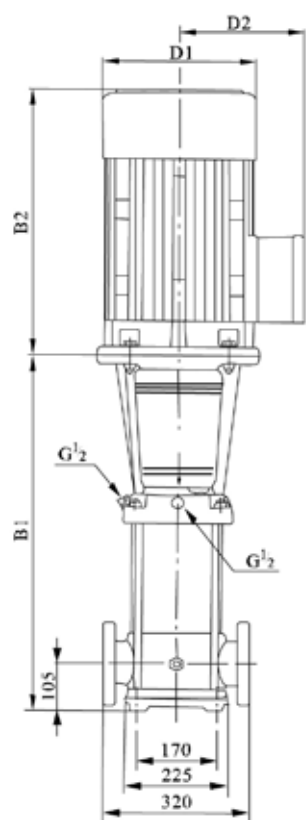

Las dimensiones exteriores en motor de una sola fase y en motor a prueba de explosiones son un poco diferentes.
Contacte con nosotros si necesita más detalles.

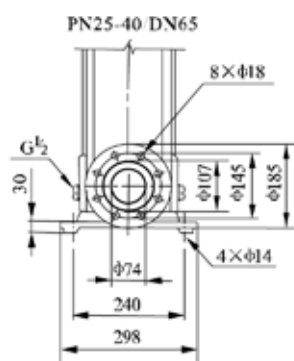

Tamaño y peso

Modelo	Dimensiones de la bomba y el motor					Peso (kg)
	B1	B2	B	D1	D2	
VF, VX, VN, VD-32-10	505	290	795	190	155	64/68
VF, VX, VN, VD-20-2/ VF, VX, VN, VD-32-20	575	345/ 355	920/ 930	197/ 230	165/ 180	77/85
VF, VX, VN, VD-32-30-2/ VF, VX, VN, VD-32-30	645	390	1035	260	208	100
VF, VX, VN, VD-32-40-2/ VF, VX, VN, VD-32-40	715	390	1105	260	208	109
VF, VX, VN, VD-32-50-2/ VF, VX, VN, VD-32-50	890	500	1390	330	255	181
VF, VX, VN, VD-32-60-2/ VF, VX, VN, VD-32-60	960	500	1460	330	255	185
VF, VX, VN, VD-32-70-2/ VF, VX, VN, VD-32-70	1030	500	1530	330	255	199
VF, VX, VN, VD-32-80-2/ VF, VX, VN, VD-32-80	1100	500	1600	330	255	203
VF, VX, VN, VD-32-90-2/ VF, VX, VN, VD-32-90	1170	550	1720	330	255	222
VF, VX, VN, VD-32-100-2/ VF, VX, VN, VD-32-100	1240	550	1790	330	255	227
VF, VX, VN, VD-32-110-2/ VF, VX, VN, VD-32-110	1310	575	1885	360	285	272
VF, VX, VN, VD-32-120-2/ VF, VX, VN, VD-32-120	1380	575	1955	360	285	276
VF, VX, VN, VD-32-130-2/ VF, VX, VN, VD-32-130	1450	650	2100	400	310	337
VF, VX, VN, VD-32-140-2/ VF, VX, VN, VD-32-140	1520	650	2170	400	310	341
VF, VX, VN, VD-32-150-2/ VF, VX, VN, VD-32-150	1590	650	2240	400	310	345
VF, VX, VN, VD-32-160-2/ VF, VX, VN, VD-32-160	1660	650	2310	400	310	350

Tabla de rendimiento

Modelo	Motor de accionamiento		Q(m³/h)	16	20	24	28	32	36	40
	(kW)	(hp)								
VF, VX, VN, VD-32-10	2,2	3	H (m)	18	17	15	14	13	11	8
VF, VX, VN, VD-32-20-2	3	4		29	28	26	23	20	16	11
VF, VX, VN, VD-32-20	4	5,5		36	34	32	29	27	23	18
VF, VX, VN, VD-32-30-2	5,5	7,5		47	44	41	39	33	28	21
VF, VX, VN, VD-32-30	5,5	7,5		54	51	48	44	40	35	27
VF, VX, VN, VD-32-40-2	7,5	10		65	62	58	53	46	40	30
VF, VX, VN, VD-32-40	7,5	10		72	69	65	59	53	47	37
VF, VX, VN, VD-32-50-2	11	15		83	79	74	68	60	52	41
VF, VX, VN, VD-32-50	11	15		90	86	81	74	67	59	47
VF, VX, VN, VD-32-60-2	11	15		101	97	80	83	74	65	51
VF, VX, VN, VD-32-60	11	15		108	104	97	90	81	72	57
VF, VX, VN, VD-32-70-2	15	20		119	114	107	98	88	78	60
VF, VX, VN, VD-32-70	15	20		126	121	113	105	95	85	67
VF, VX, VN, VD-32-80-2	15	20		136	131	123	114	102	90	71
VF, VX, VN, VD-32-80	15	20		144	138	130	120	109	97	77
VF, VX, VN, VD-32-90-2	18,5	25		154	148	140	129	117	102	82
VF, VX, VN, VD-32-90	18,5	25		162	156	147	136	124	109	88
VF, VX, VN, VD-32-100-2	18,5	25		175	166	157	146	131	115	91
VF, VX, VN, VD-32-100	18,5	25		182	173	164	152	138	122	98
VF, VX, VN, VD-32-110-2	22	30		193	184	173	164	146	128	102
VF, VX, VN, VD-32-110	22	30		200	191	180	168	153	135	109
VF, VX, VN, VD-32-120-2	22	30		211	201	189	178	160	140	113
VF, VX, VN, VD-32-120	22	30		218	208	196	184	167	147	120
VF, VX, VN, VD-32-130-2	30	40		230	228	206	193	174	153	124
VF, VX, VN, VD-32-130	30	40		237	225	213	200	181	160	131
VF, VX, VN, VD-32-140-2	30	40		247	235	222	210	189	165	135
VF, VX, VN, VD-32-140	30	40		255	242	229	216	196	172	142
VF, VX, VN, VD-32-150-2	30	40		266	253	239	224	203	178	145
VF, VX, VN, VD-32-150	30	40		274	260	246	231	210	185	152
VF, VX, VN, VD-32-160-2	30	40		284	270	255	240	218	190	156
VF, VX, VN, VD-32-160	30	40	292	277	262	246	225	197	163	

Curva de rendimiento ISO9906:2012 Grado 3B

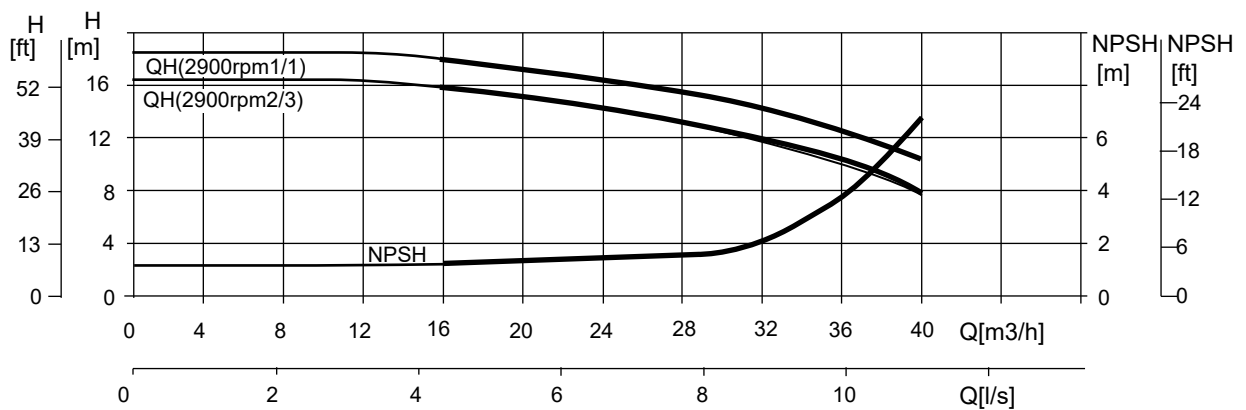
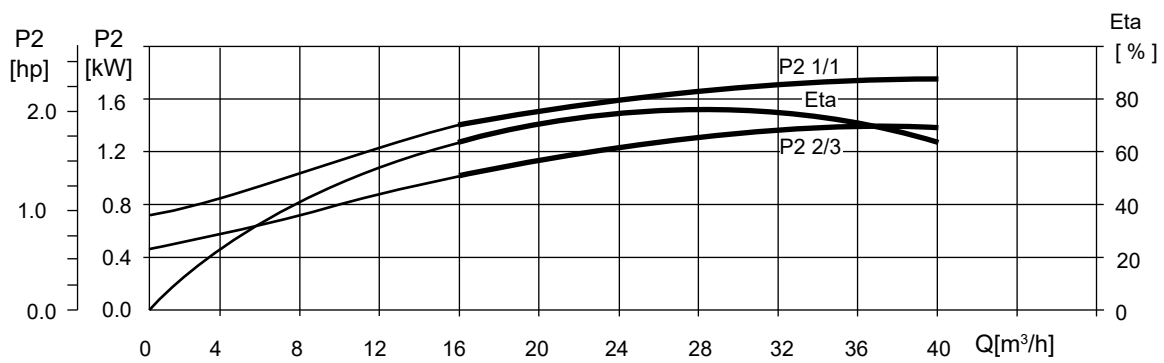
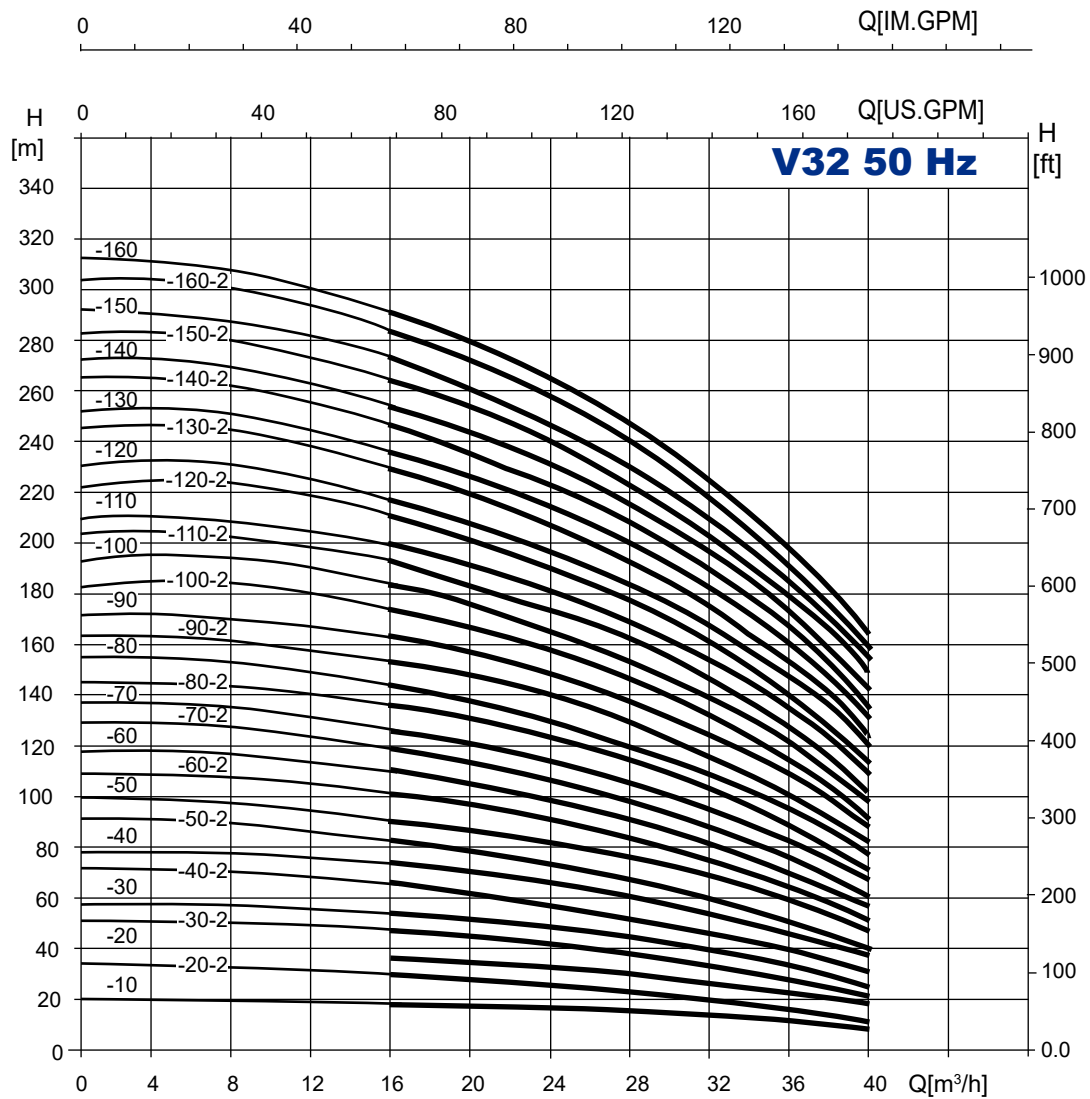

V/F-X-N-D 45

Esquema de instalación

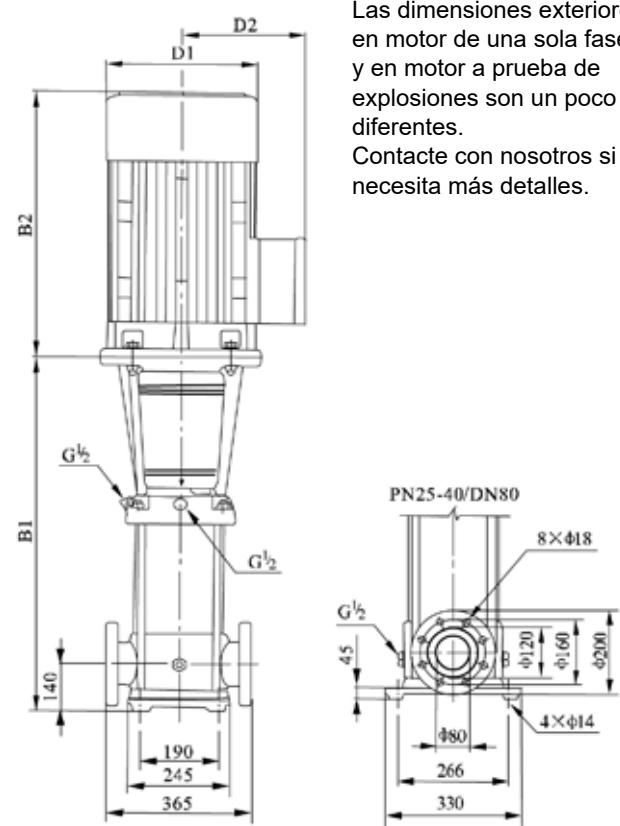

Las dimensiones exteriores en motor de una sola fase y en motor a prueba de explosiones son un poco diferentes.

Contacte con nosotros si necesita más detalles.

Tamaño y peso

Modelo	Dimensiones de la bomba y el motor					Peso (kg)
	B1	B2	B	D1	D2	
VF, VX, VN, VD-45-10	561	345/355	906/916	197/230	165/188	83/90
VF, VX, VN, VD-45-20-2/ VF, VX, VN, VD-45-20	641	390	1031	260	208	105/110
VF, VX, VN, VD-45-30-2/ VF, VX, VN, VD-45-30	826	500	1326	330	255	183
VF, VX, VN, VD-45-40-2/ VF, VX, VN, VD-45-40	906	500	1406	330	255	197
VF, VX, VN, VD-45-50-2/ VF, VX, VN, VD-45-50	986	550	1536	330	255	221
VF, VX, VN, VD-45-60-2/ VF, VX, VN, VD-45-60	1066	575	1641	360	285	261
VF, VX, VN, VD-45-70-2/ VF, VX, VN, VD-45-70	1046	650	1796	400	310	320
VF, VX, VN, VD-45-80-2/ VF, VX, VN, VD-45-80	1226	650	1876	400	310	324
VF, VX, VN, VD-45-90-2/ VF, VX, VN, VD-45-90	1306	650	1956	400	310	328/352
VF, VX, VN, VD-45-100-2/ VF, VX, VN, VD-45-100	1386	650	2036	400	310	355
VF, VX, VN, VD-45-110-2/ VF, VX, VN, VD-45-110	1466	685	2151	450	345	426
VF, VX, VN, VD-45-120-2/ VF, VX, VN, VD-45-120	1546	685	2231	450	345	432
VF, VX, VN, VD-45-130-2	1626	650	2311	450	345	438

Tabla de rendimiento

Modelo	Motor de accionamiento		Q(m³/h)	25	30	35	40	45	45	50	55
	(kW)	(hp)									
VF, VX, VN, VD-45-10	4	5,5	H (m)	24	26	22	21	20	19	18	16
VF, VX, VN, VD-45-20-2	5,5	7,5		40	38	36	33	32	30	27	23
VF, VX, VN, VD-45-20	7,5	10		48	46	44	42	41	39	35	31
VF, VX, VN, VD-45-30-2	11	15		63	31	58	54	52	50	44	38
VF, VX, VN, VD-45-30	11	15		71	69	66	63	61	58	53	47
VF, VX, VN, VD-45-40-2	15	20		87	84	80	75	73	69	62	54
VF, VX, VN, VD-45-40	15	20		95	92	88	84	81	78	71	62
VF, VX, VN, VD-45-50-2	18,5	25		111	107	102	96	93	88	80	69
VF, VX, VN, VD-45-50	18,5	25		119	115	110	105	101	97	88	78
VF, VX, VN, VD-45-60-2	22	30		135	130	124	117	113	108	97	85
VF, VX, VN, VD-45-60	22	30		143	138	132	125	122	116	106	93
VF, VX, VN, VD-45-70-2	30	40		158	152	146	138	134	127	115	100
VF, VX, VN, VD-45-70	30	40		166	161	154	146	142	135	124	109
VF, VX, VN, VD-45-80-2	30	40		182	175	168	159	154	146	133	116
VF, VX, VN, VD-45-80	30	40		190	184	176	167	162	154	141	124
VF, VX, VN, VD-45-90-2	30	40		205	198	190	180	174	166	150	132
VF, VX, VN, VD-45-90	37	50		214	207	198	188	183	174	159	140
VF, VX, VN, VD-45-100-2	37	50		230	221	212	200	194	185	168	147
VF, VX, VN, VD-45-100	37	50		238	230	220	209	203	193	177	155
VF, VX, VN, VD-45-110-2	45	60		255	246	236	223	217	206	188	165
VF, VX, VN, VD-45-110	45	60	263	255	244	232	225	214	196	173	
VF, VX, VN, VD-45-120-2	45	60	280	270	259	245	238	226	206	181	
VF, VX, VN, VD-45-120	45	60	289	280	268	255	247	236	216	190	
VF, VX, VN, VD-45-130-2	45	60	305	294	282	267	259	247	225	198	

Curva de rendimiento ISO9906:2012 Grado 3B

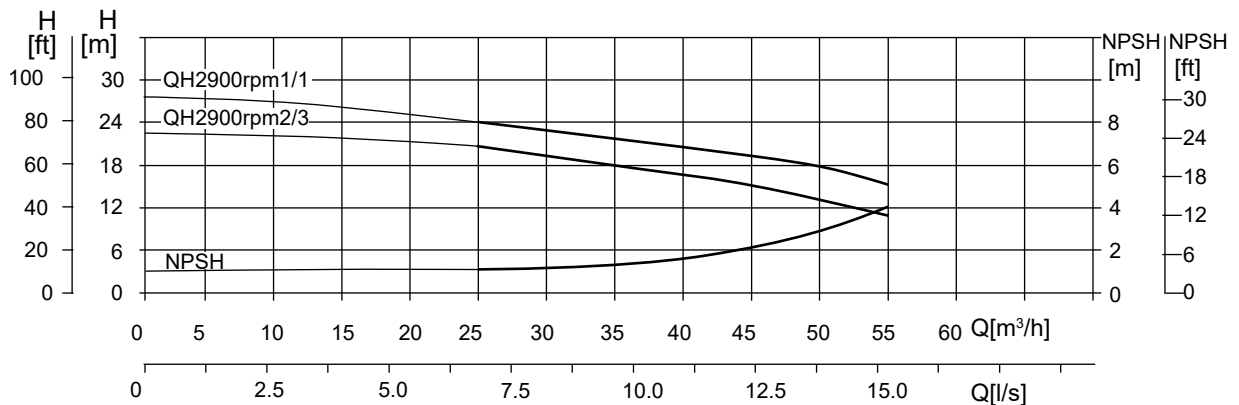
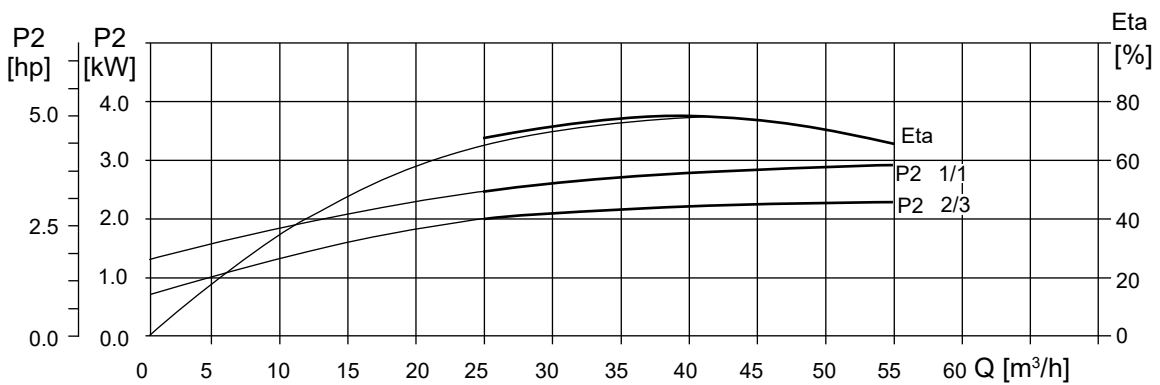
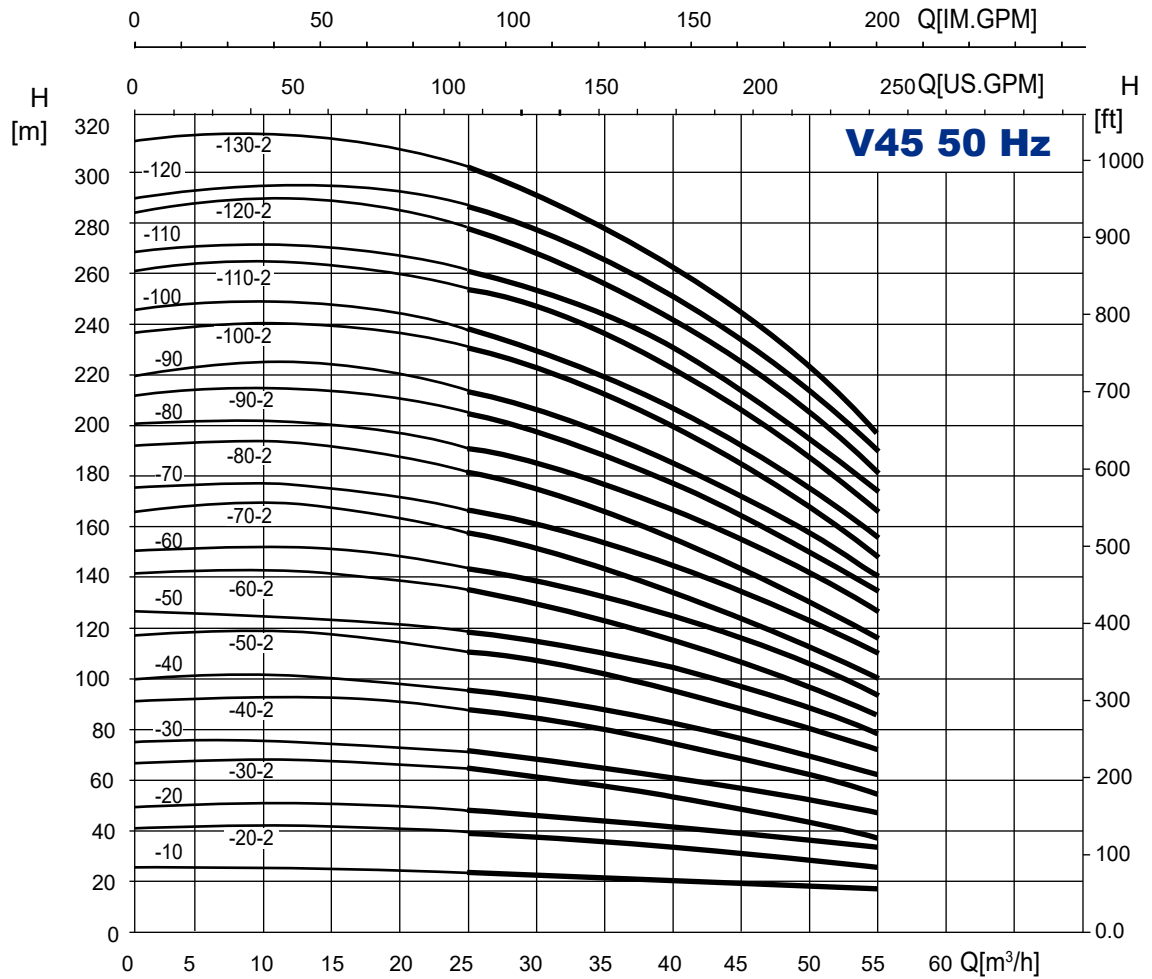

V/F-X-N-D 65

Esquema de instalación

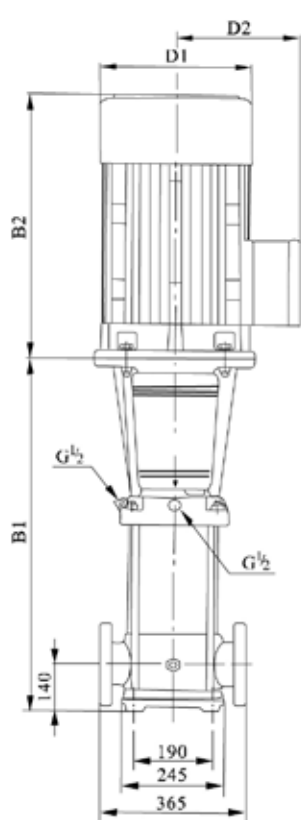

Las dimensiones exteriores en motor de una sola fase y en motor a prueba de explosiones son un poco diferentes.
Contacte con nosotros si necesita más detalles.

Brida estándar PN25-40/ DN100 disponible si se solicita.

Tamaño y peso

Modelo	Dimensiones de la bomba y el motor					Peso (kg)
	B1	B2	B	D1	D2	
VF, VX, VN, VD-65-10-1	561	335	916	230	188	93
VF, VX, VN, VD-65-10	561	390	951	260	208	105
VF, VX, VN, VD-65-20-2	644	390	1034	260	208	110
VF, VX, VN, VD-65-20-1	754	500	1254	3030	255	182
VF, VX, VN, VD-65-20	754	500	1254	330	255	182
VF, VX, VN, VD-65-30-2	836	500	1336	330	255	196
VF, VX, VN, VD-65-30-1	836	500	1336	330	255	197
VF, VX, VN, VD-65-30	836	550	1386	330	255	221
VF, VX, VN, VD-65-40-2	919	550	1469	330	255	225
VF, VX, VN, VD-65-40-1	919	575	1494	360	285	258
VF, VX, VN, VD-65-40	919	575	1494	360	285	258
VF, VX, VN, VD-65-50-2	1001	650	1651	400	310	319
VF, VX, VN, VD-65-50-1	1001	650	1651	400	310	319
VF, VX, VN, VD-65-50	1001	650	1651	400	310	320
VF, VX, VN, VD-65-60-2	1084	650	1734	400	310	325
VF, VX, VN, VD-65-60-1	1084	650	1734	400	310	349
VF, VX, VN, VD-65-60	1084	650	1374	400	310	349
VF, VX, VN, VD-65-70-2	1166	650	1816	400	310	353
VF, VX, VN, VD-65-70-1	1166	650	1816	400	310	353
VF, VX, VN, VD-65-70	1166	685	1851	460	340	420
VF, VX, VN, VD-65-80-2	1248	685	1933	460	340	424
VF, VX, VN, VD-65-80-1	1248	685	1933	460	340	424

Tabla de rendimiento

Modelo	Motor de accionamiento		Q(m³/h)	30	40	50	60	65	70	80
	(kW)	(hp)								
VF, VX, VN, VD-65-10-1	4	5,5	H (m)	19	18	16	14	13	11	8
VF, VX, VN, VD-65-10	5,5	7,5		27	25	23	21	20	18	15
VF, VX, VN, VD-65-20-2	7,5	10		39	36	33	29	26	23	17
VF, VX, VN, VD-65-20-1	11	15		46	44	40	36	33	30	24
VF, VX, VN, VD-65-20	11	15		53	51	47	43	40	37	30
VF, VX, VN, VD-65-30-2	15	20		66	62	56	50	45	41	32
VF, VX, VN, VD-65-30-1	15	20		73	69	63	57	53	48	39
VF, VX, VN, VD-65-30	18,5	25		80	76	70	64	60	55	46
VF, VX, VN, VD-65-40-2	18,5	25		92	87	80	71	66	60	47
VF, VX, VN, VD-65-40-1	22	30		100	94	87	78	73	67	54
VF, VX, VN, VD-65-40	22	30		107	101	94	85	80	74	61
VF, VX, VN, VD-65-50-2	30	40		121	114	105	95	88	80	64
VF, VX, VN, VD-65-50-1	30	40		128	121	112	102	95	87	71
VF, VX, VN, VD-65-50	30	40		136	129	119	109	102	94	78
VF, VX, VN, VD-65-60-2	30	40		150	142	131	118	110	101	81
VF, VX, VN, VD-65-60-1	37	50		157	149	138	125	117	108	88
VF, VX, VN, VD-65-60	37	50		164	156	145	132	124	115	95
VF, VX, VN, VD-65-70-2	37	50		179	169	156	141	132	121	99
VF, VX, VN, VD-65-70-1	37	50		186	176	163	148	139	128	106
VF, VX, VN, VD-65-70	45	60		193	183	170	155	146	135	112
VF, VX, VN, VD-65-80-2	45	60	207	196	182	164	154	142	116	
VF, VX, VN, VD-65-80-1	45	60	215	203	189	171	161	149	123	

Curva de rendimiento ISO9906:2012 Grado 3B

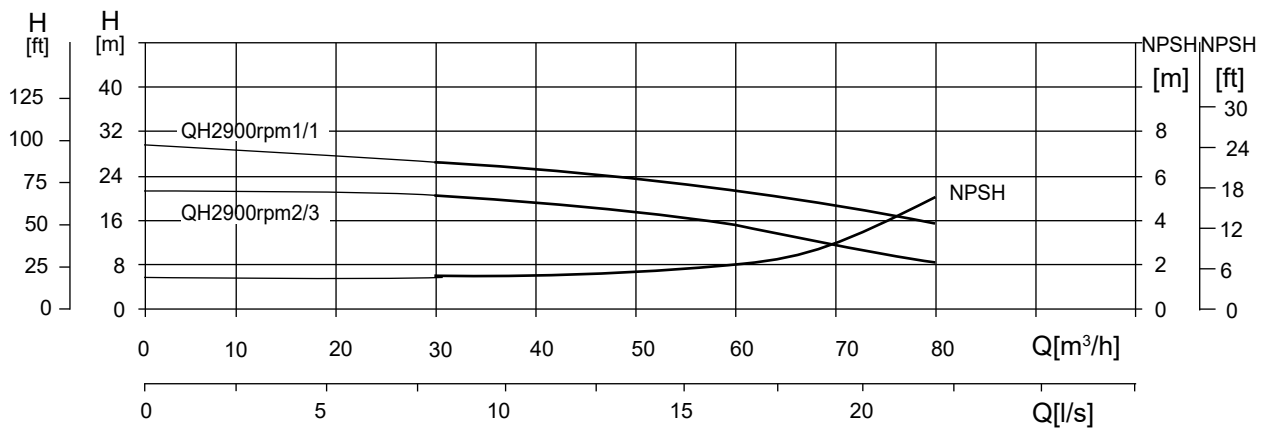
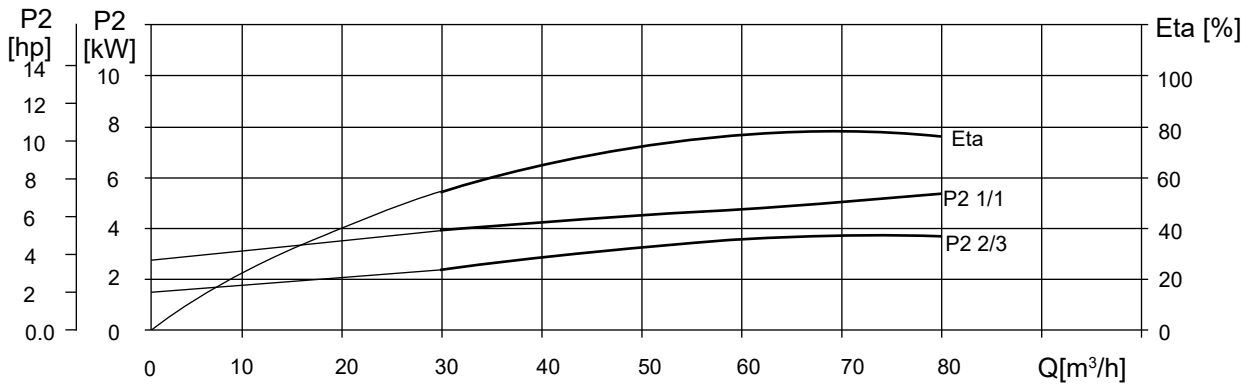
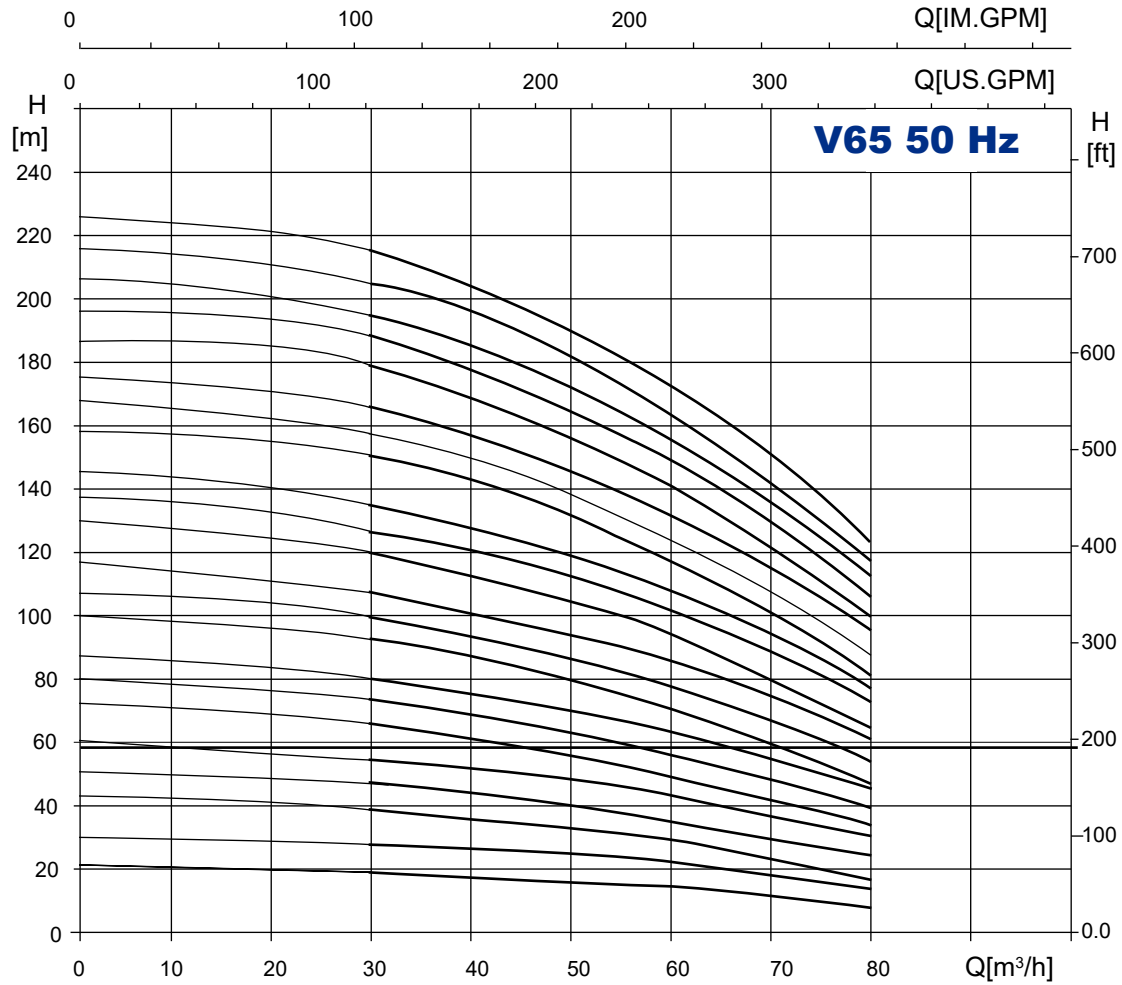

V/F-X-N-D 90

Esquema de instalación

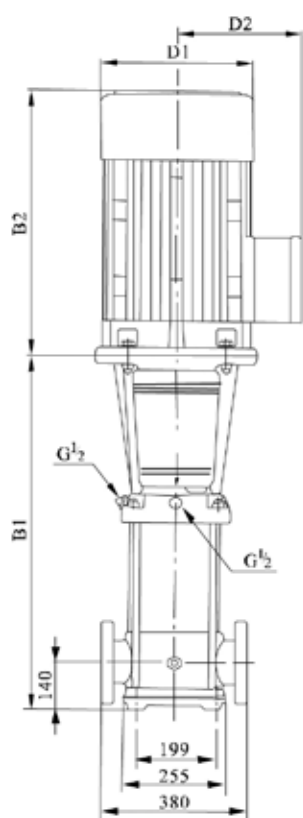

Las dimensiones exteriores en motor de una sola fase y en motor a prueba de explosiones son un poco diferentes.

Contacte con nosotros si necesita más detalles.

Brida estándar PN25-40/ DN100 disponible si se solicita.

Tamaño y peso

Modelo	Dimensiones de la bomba y el motor					Peso (kg)
	B1	B2	B	D1	D2	
VF, VX, VN, VD-90-10-1	571	390	961	260	208	105
VF, VX, VN, VD-90-10	571	390	961	260	208	110
VF, VX, VN, VD-90-20-2	773	500	1273	330	255	181
VF, VX, VN, VD-90-20	773	500	1273	330	255	192
VF, VX, VN, VD-90-30-2	865	550	1415	330	255	215
VF, VX, VN, VD-90-30	865	575	1440	360	285	252
VF, VX, VN, VD-90-40-2	957	650	1607	400	310	312
VF, VX, VN, VD-90-40	957	650	1607	400	310	312
VF, VX, VN, VD-90-50-2	1049	650	1699	400	310	336
VF, VX, VN, VD-90-50	1049	650	1699	400	310	336
VF, VX, VN, VD-90-60-2	1141	685	1826	460	340	407
VF, VX, VN, VD-90-60	1141	685	1826	460	340	407

Tabla de rendimiento

Modelo	Motor de accionamiento		Q(m³/h)	50	60	70	80	85	90	100	110
	(kW)	(hp)									
VF, VX, VN, VD-90-10-1	5,5	7,5	H (m)	22	19	17	16	14	13	10	6
VF, VX, VN, VD-90-10	7,5	10		25	24	22	21	20	19	16	12
VF, VX, VN, VD-90-20-2	11	15		41	39	36	32	30	28	22	15
VF, VX, VN, VD-90-20	15	20		53	50	47	44	41	40	36	30
VF, VX, VN, VD-90-30-2	18,5	25		68	65	60	55	52	49	41	32
VF, VX, VN, VD-90-30	22	30		81	77	72	67	64	62	55	48
VF, VX, VN, VD-90-40-2	30	40		98	93	87	80	75	72	62	50
VF, VX, VN, VD-90-40	30	40		110	105	100	92	86	84	76	66
VF, VX, VN, VD-90-50-2	37	50		126	120	113	104	98	93	81	68
VF, VX, VN, VD-90-50	37	50		139	131	124	115	110	106	94	83
VF, VX, VN, VD-90-60-2	45	60		155	148	139	129	122	117	102	85
VF, VX, VN, VD-90-60	45	60		168	160	150	141	134	130	117	103

Curva de rendimiento ISO9906:2012 Grado 3B

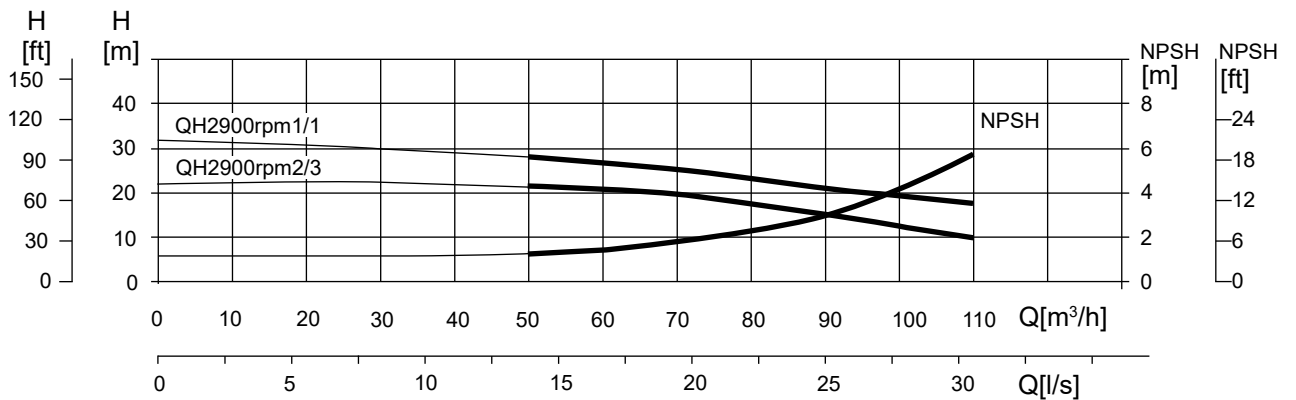
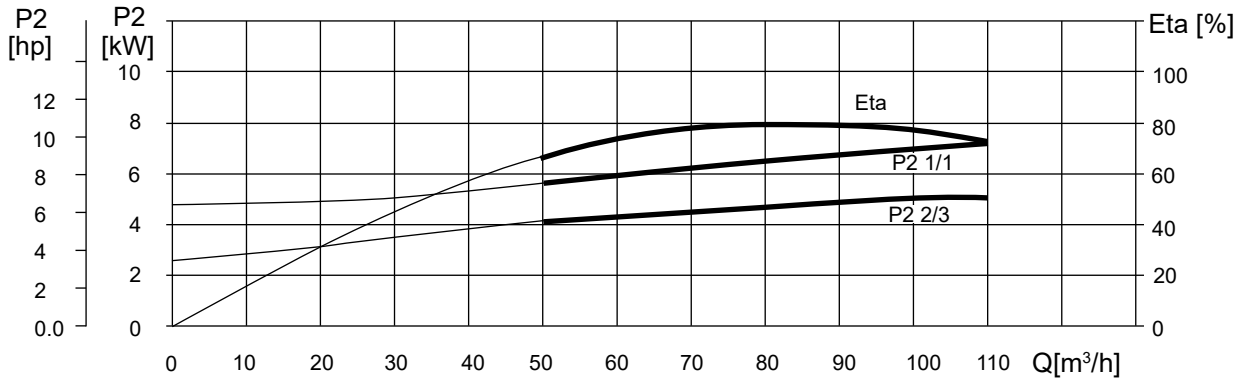
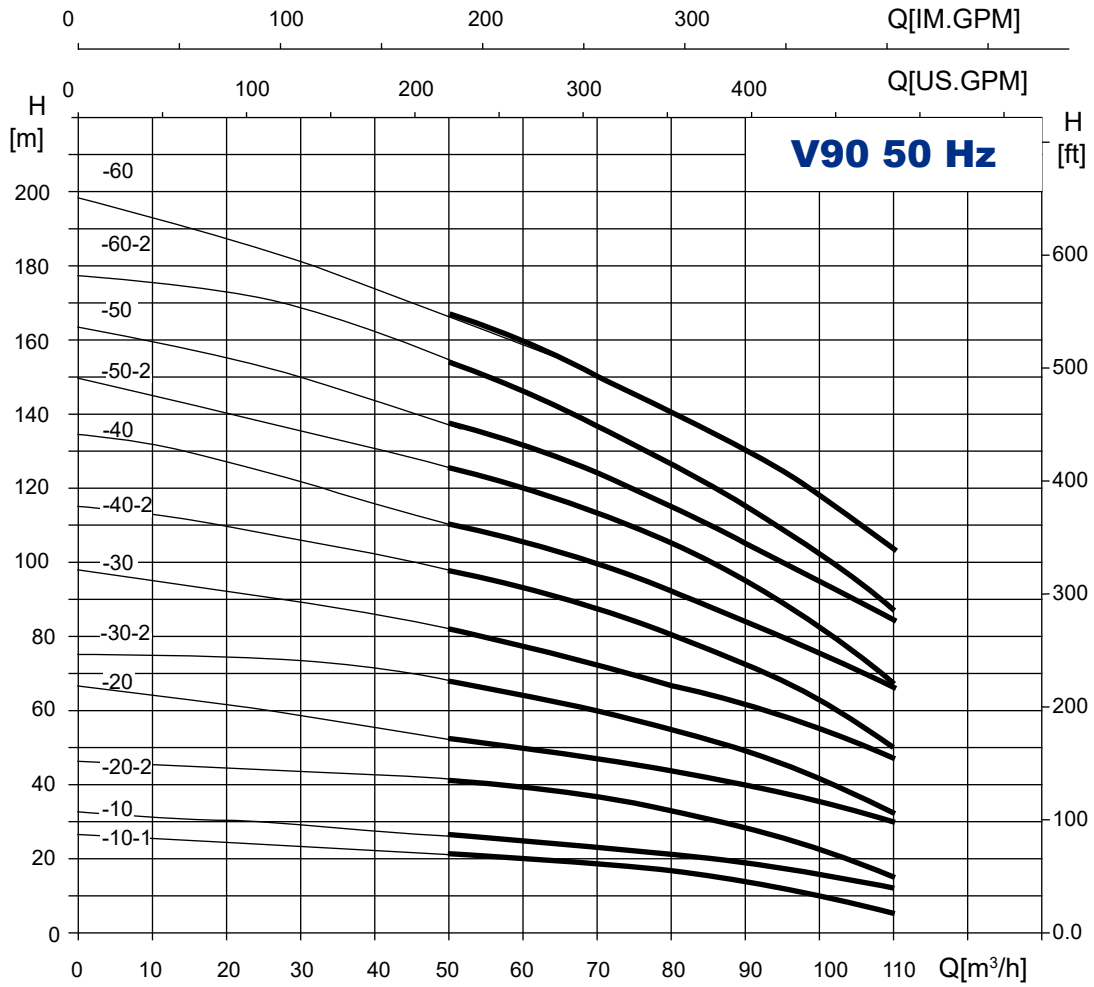

V/F-X-N-D 125

Esquema de instalación

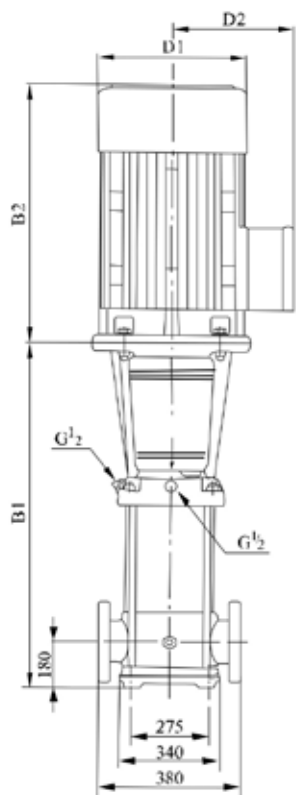

Las dimensiones exteriores en motor de una sola fase y en motor a prueba de explosiones son un poco diferentes.

Contacte con nosotros si necesita más detalles.

Tamaño y peso

Modelo	Dimensiones de la bomba y el motor					Peso (kg)
	B1	B2	B	D1	D2	
VF, VX, VN, VD-125-10	840	500	1340	330	255	230
VF, VX, VN, VD-125-20-2	1000	500	1500	330	255	245
VF, VX, VN, VD-125-20-1	1000	550	1550	330	255	250
VF, VX, VN, VD-125-20	1000	575	1575	360	285	285
VF, VX, VN, VD-125-30-2	1160	650	1810	400	310	360
VF, VX, VN, VD-125-30-1	1160	650	1810	400	310	360
VF, VX, VN, VD-125-30	1160	650	1810	400	310	360
VF, VX, VN, VD-125-50-2	1320	650	1970	400	310	400
VF, VX, VN, VD-125-40-1	1320	650	1970	400	310	400
VF, VX, VN, VD-125-40	1320	685	2005	400	340	460
VF, VX, VN, VD-125-50-2	1480	685	2165	460	340	470
VF, VX, VN, VD-125-50-1	1480	685	2165	460	340	470
VF, VX, VN, VD-125-50	1510	760	2270	460	370	575
VF, VX, VN, VD-125-60-2	1670	760	2430	540	370	585
VF, VX, VN, VD-125-60-1	1670	760	2430	540	370	585
VF, VX, VN, VD-125-60	1670	845	2515	540	410	705
VF, VX, VN, VD-125-70-2	1830	845	2675	580	410	715
VF, VX, VN, VD-125-70-1	1830	845	2675	580	410	715
VF, VX, VN, VD-125-70	1830	845	2675	580	410	715

Tabla de rendimiento

Modelo	Motor de accionamiento		Q(m ³ /h)	60	70	80	90	100	110	120	130	140	150
	(kW)	(hp)											
VF, VX, VN, VD-125-10	11	15	H (m)	22	21,8	21,6	21	20,5	19,5	18,5	17	16	15
VF, VX, VN, VD-125-20-2	15	20		34	33,6	33	31	30,2	30	28,5	28	25	24
VF, VX, VN, VD-125-20-1	18,5	25		41	40	39,5	38,5	37	36,5	34,5	32,5	30	27,5
VF, VX, VN, VD-125-20	22	30		46	45	44,5	43,5	42,4	41	40	38	36	33,5
VF, VX, VN, VD-125-30-2	30	40		57	56	55	53,5	52	51	49	46,5	43,5	41
VF, VX, VN, VD-125-30-1	30	40		64	63	62	60	58,5	57,5	55,5	52	49	46
VF, VX, VN, VD-125-30	30	40		69,5	68,5	67,5	66	64	62,5	61	57,5	54,5	51
VF, VX, VN, VD-125-40-2	37	50		80,5	79	78	76	73,5	72	69	66	61,5	58
VF, VX, VN, VD-125-40-1	37	50		87	86	84,5	82	80	78	76	72	68	64,5
VF, VX, VN, VD-125-40	45	60		92,5	91	90	88	85,5	83	81	77	73	68,5
VF, VX, VN, VD-125-50-2	45	60		104,5	103	101	99	96	93	90	85,5	80,5	75,5
VF, VX, VN, VD-125-50-1	45	60		110,5	109	107,5	105	102	100	97	90	86,5	83
VF, VX, VN, VD-125-50	55	75		115,5	114	113	110	107,5	104,5	101,5	96	91	86
VF, VX, VN, VD-125-60-2	55	75		128	125,5	123	121	117,3	113,5	110	104,5	98,5	92,5
VF, VX, VN, VD-125-60-1	55	75		134	132	130,5	127	124	121	118	111	105	100
VF, VX, VN, VD-125-60	75	100		139	137	135	132	128,8	126	123	116	110	104
VF, VX, VN, VD-125-70-2	75	100		151	148	145,5	143	139,6	134	130	123,5	116,5	109
VF, VX, VN, VD-125-70-1	75	100		156,5	154	152	148,5	144,5	141	137,5	130	123	116,5
VF, VX, VN, VD-125-70	75	100		162,5	160,5	158,5	155	151	148	145	137	129	123

Curva de rendimiento ISO9906:2012 Grado 3B

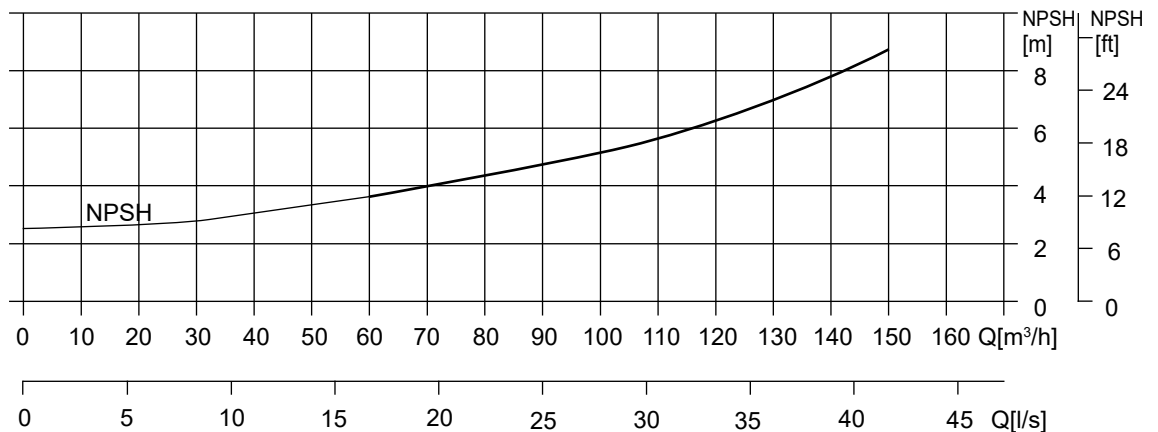
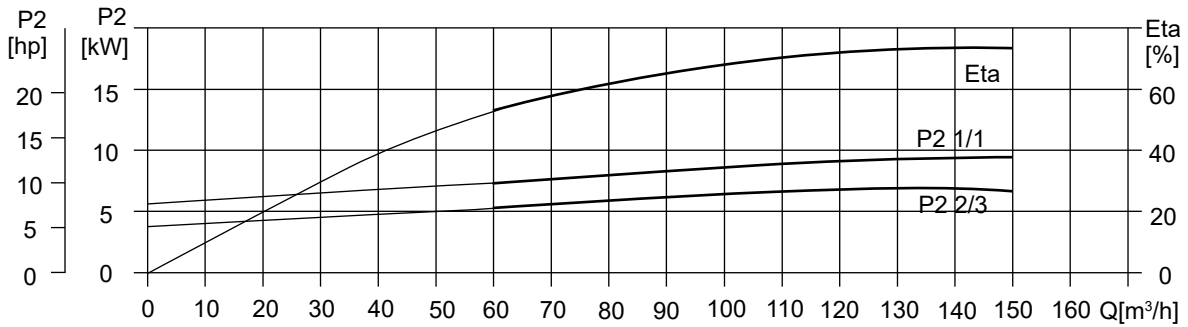
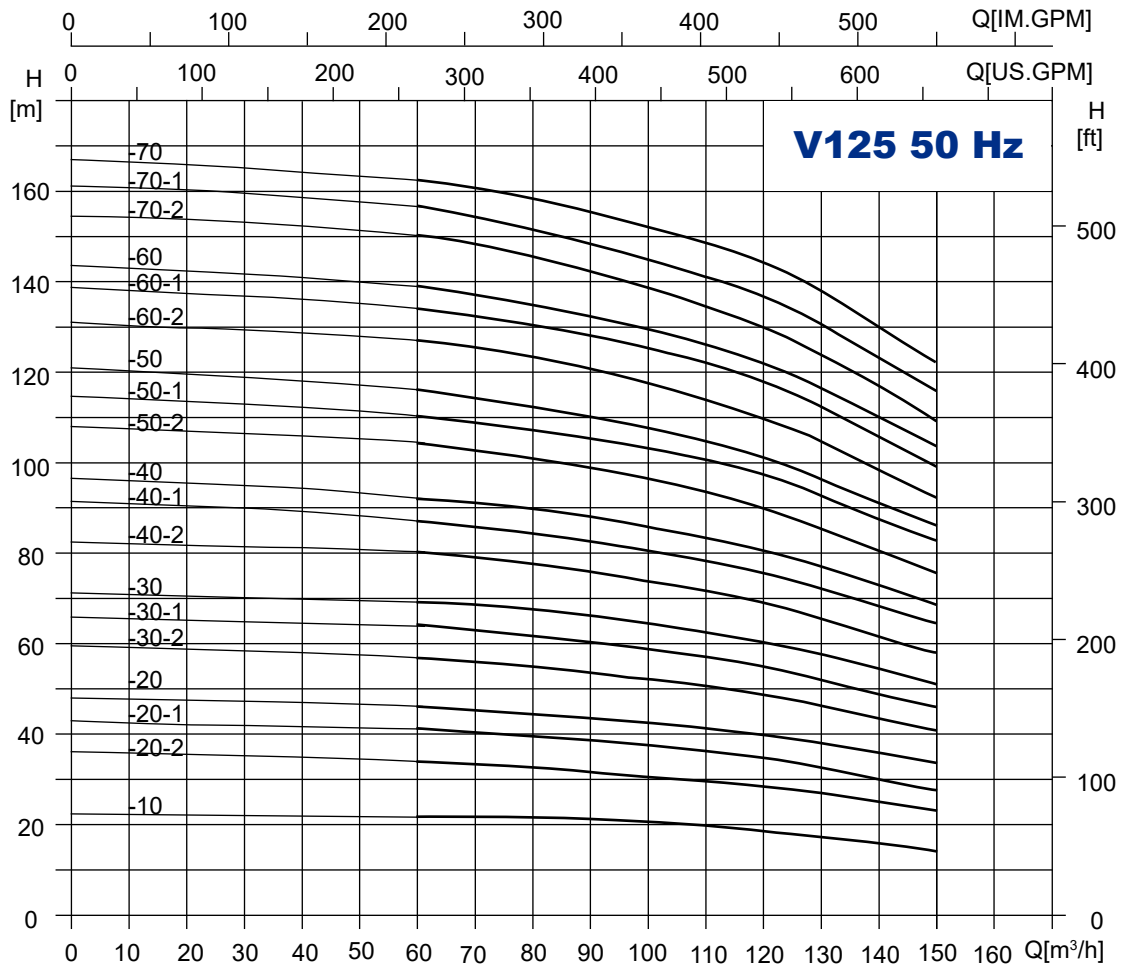

V/F-X-N-D 150

Esquema de instalación

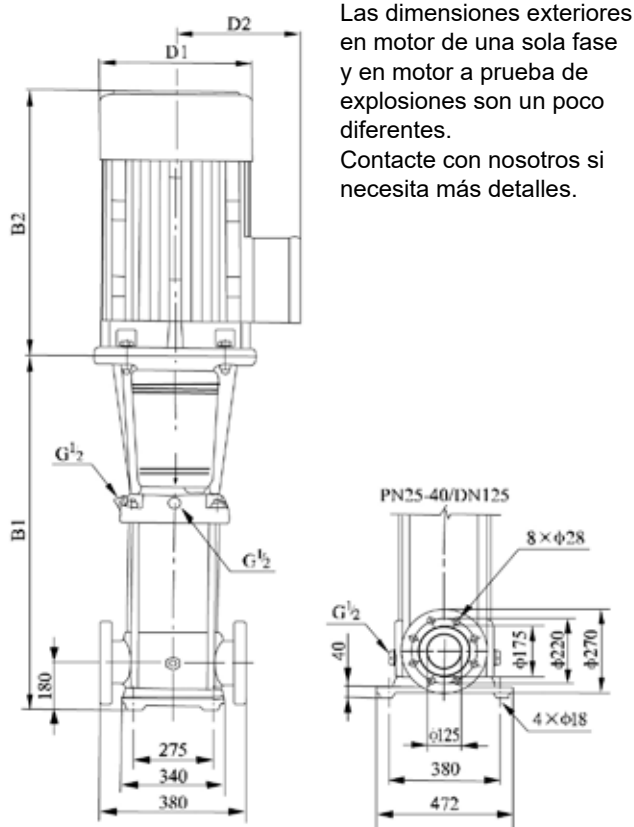

Tamaño y peso

Modelo	Dimensiones de la bomba y el motor					Peso (kg)
	B1	B2	B	D1	D2	
VF, VX, VN, VD-150-10-1	840	500	1340	330	255	230
VF, VX, VN, VD-150-10	840	500	1340	330	255	235
VF, VX, VN, VD-150-20-2	1000	550	1550	330	255	250
VF, VX, VN, VD-150-20-1	1000	575	1575	360	285	295
VF, VX, VN, VD-150-20	1000	650	1650	400	310	350
VF, VX, VN, VD-150-30-2	1160	650	1810	400	310	360
VF, VX, VN, VD-150-30-1	1160	650	1810	400	310	360
VF, VX, VN, VD-150-30	1160	650	1810	400	310	385
VF, VX, VN, VD-150-40-2	1320	685	2005	460	310	460
VF, VX, VN, VD-150-40-1	1320	685	2005	460	340	460
VF, VX, VN, VD-150-40	1350	760	2110	540	340	560
VF, VX, VN, VD-150-50-2	1510	760	2270	540	370	570
VF, VX, VN, VD-150-50-1	1510	845	2355	580	410	690
VF, VX, VN, VD-150-50	1510	845	2355	580	410	690
VF, VX, VN, VD-150-60-2	1670	845	2515	580	410	700
VF, VX, VN, VD-150-60-1	1670	845	2515	580	410	700
VF, VX, VN, VD-150-60	1670	845	2515	580	410	700

Tabla de rendimiento

Modelo	Motor de accionamiento		Q(m³/h)	80	90	100	110	120	130	140	150	160	170	180
	(kW)	(hp)												
VF, VX, VN, VD-150-10-1	11	15	H (m)	18,3	17,8	17,3	17	16	15	14	12,5	11	10	8,5
VF, VX, VN, VD-150-10	15	20		24	23	22,5	22	21,5	20,5	20	18,5	17	16	15
VF, VX, VN, VD-150-20-2	18,5	25		37	35,5	34	33	32	31	29	27,5	36	23	21
VF, VX, VN, VD-150-20-1	22	30		44,3	43	43	40	39	38,5	37,5	35	33	30	27
VF, VX, VN, VD-150-20	30	40		50	49	48	47	45,5	44	42	40	37	34	32
VF, VX, VN, VD-150-30-2	30	40		63,5	61	59	57,5	56	54,5	53	49	45,5	42	39
VF, VX, VN, VD-150-30-1	37	50		70	68	67	65	63	62	60	56	53	49	45
VF, VX, VN, VD-150-30	37	50		78	76,5	75	73	70,5	98	66	63	59	55	50,5
VF, VX, VN, VD-150-40-2	45	60		89	87	84	81,5	79	77	74,5	70,5	65,5	60	56
VF, VX, VN, VD-150-40-1	45	60		96,5	94	91,5	89	86,5	84	81,5	77	72,5	67	62
VF, VX, VN, VD-150-40	55	75		104	102	100	97	95	91	88	84	79,5	74	68
VF, VX, VN, VD-150-50-2	55	75		115,5	112	109	106	102,5	100	97	92	86	79	73,5
VF, VX, VN, VD-150-50-1	75	100		122,5	119,5	117	113,5	111,5	107,5	104,5	99	93,5	87	80
VF, VX, VN, VD-150-50	75	100		130	127,5	125	121	119	115	111,5	106,5	101	94,5	86,5
VF, VX, VN, VD-150-60-2	75	100		140	137	133	130	126	121	118	112	106	98	91
VF, VX, VN, VD-150-60-1	75	100		148,5	145	141,7	137,5	135	131	127	120,5	114,5	106,5	97,5
VF, VX, VN, VD-150-60	75	100		157	153	149	145	142	139,5	137	130	123,5	116	109

Curva de rendimiento ISO9906:2012 Grado 3B

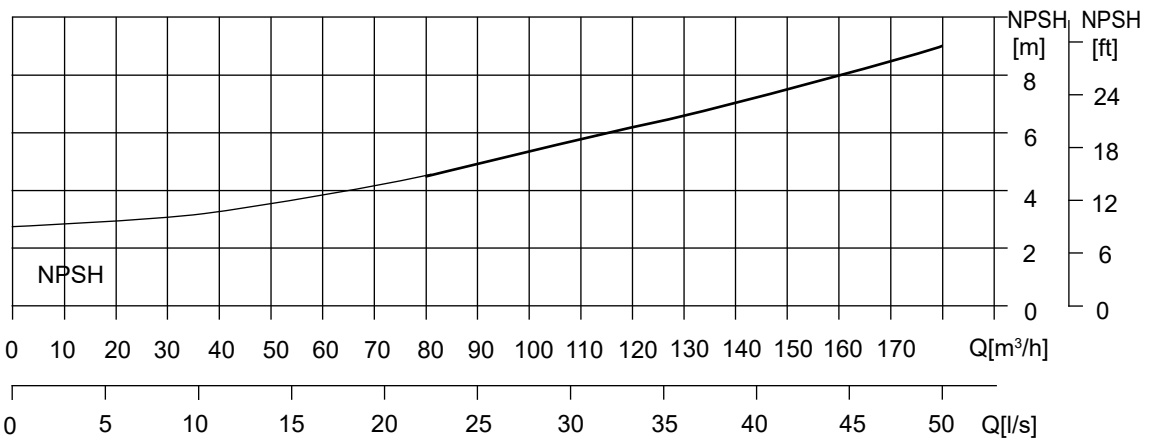
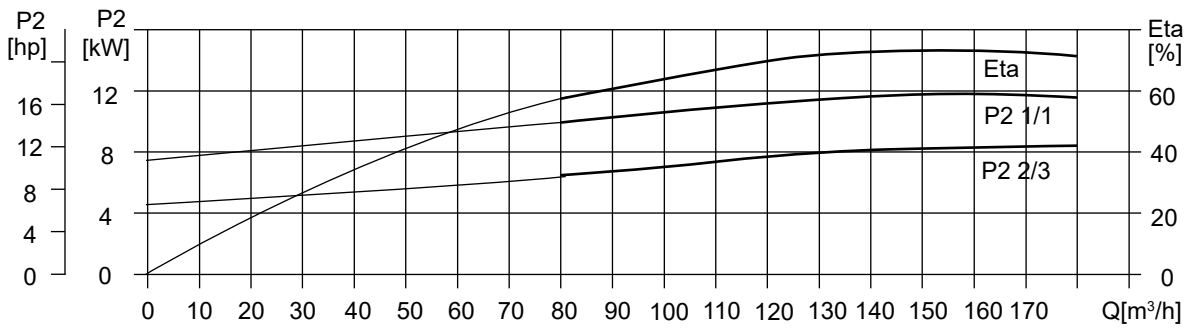
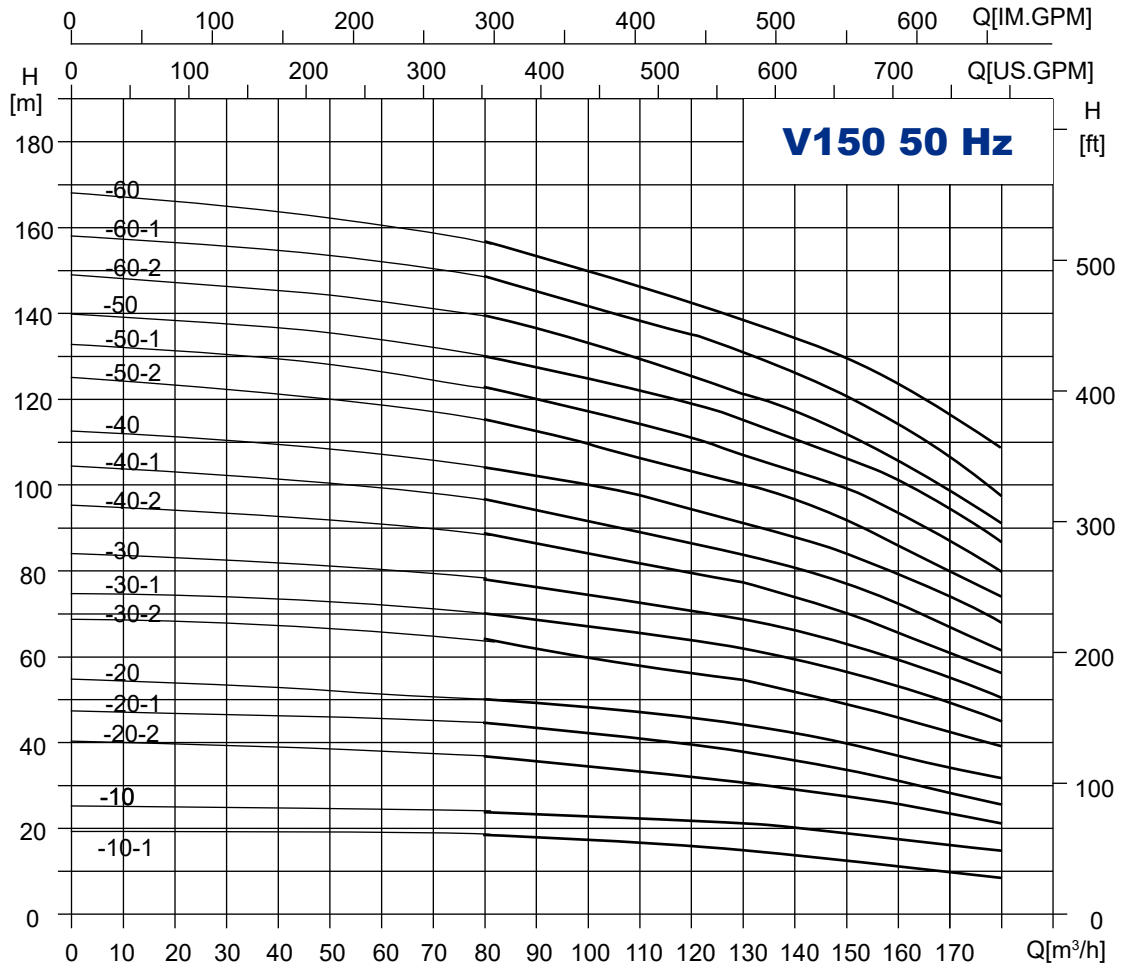

V/F-X-N-D 210

Esquema de instalación

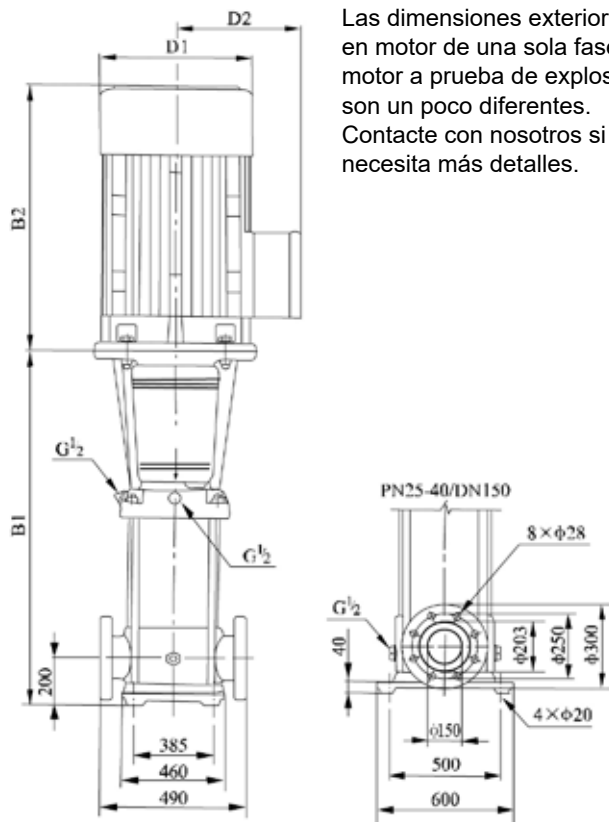

Las dimensiones exteriores en motor de una sola fase y en motor a prueba de explosiones son un poco diferentes. Contacte con nosotros si necesita más detalles.

Tamaño y peso

Modelo	Dimensiones de la bomba y el motor					Peso (kg)
	B1	B2	B	D1	D2	
VF, VX, VN, VD-210-10-B	907	550	1457	330	255	311
VF, VX, VN, VD-210-10-A	907	575	1482	360	285	347
VF, VX, VN, VD-210-10	907	650	1557	400	310	403
VF, VX, VN, VD-210-20-2B	1101	650	1751	400	310	447
VF, VX, VN, VD-210-20-2A	1101	685	1786	460	340	504
VF, VX, VN, VD-210-20-A	1131	760	1891	540	370	595
VF, VX, VN, VD-210-20	1131	760	1891	540	370	595
VF, VX, VN, VD-210-30-2B	1325	845	2170	580	410	748
VF, VX, VN, VD-210-30-A-B	1325	845	2170	580	410	748
VF, VX, VN, VD-210-30-2A	1325	845	2170	580	410	748
VF, VX, VN, VD-210-30-B	1325	845	2170	580	410	748
VF, VX, VN, VD-210-30-A	1325	845	2170	580	410	748
VF, VX, VN, VD-210-30	1325	845	2220	580	410	817
VF, VX, VN, VD-210-40-2B	1519	1140	2414	580	410	830
VF, VX, VN, VD-210-40-2A	1519	1140	2659	645	550	1180
VF, VX, VN, VD-210-40-A	1519	1140	2659	645	550	1180
VF, VX, VN, VD-210-40	1519	1140	2659	645	550	1180

Tabla de rendimiento

Modelo	Motor de accionamiento		Q(m³/h)	100	120	140	160	180	200	220	240
	(kW)	(hp)									
VF, VX, VN, VD-210-10-B	18,5	25	H (m)	25,5	25	24	23	21,5	20	18	15,5
VF, VX, VN, VD-210-10-A	22	30		29	28,5	27,5	26,5	25,5	24	22	20
VF, VX, VN, VD-210-10	30	40		38,5	38	37,5	36,5	35	32	32,5	30
VF, VX, VN, VD-210-20-2B	37	50		53	51	49	47	44	41	37	32
VF, VX, VN, VD-210-20-2A	45	60		59,5	58	56	54	52,5	49	44,5	40,5
VF, VX, VN, VD-210-20-A	55	75		69	68	66	64	62	59	55,5	51
VF, VX, VN, VD-210-20	55	75		78,5	77,5	76	74	71,5	69	66	61,5
VF, VX, VN, VD-210-30-2B	75	100		91,5	89	87	83,5	79	75	70	63
VF, VX, VN, VD-210-30-A-B	75	100		95	93	90	87	83,5	79	73,5	67
VF, VX, VN, VD-210-30-2A	75	100		99,5	97,5	94,5	91,5	89	84	78,5	72
VF, VX, VN, VD-210-30-B	75	100		104,5	102,5	100	97	93	89	84,5	77,5
VF, VX, VN, VD-210-30-A	75	100		108	106	103,5	100,5	97,5	93	88	81,5
VF, VX, VN, VD-210-30	90	120		117,5	116	113,5	110,5	107	103	99	92
VF, VX, VN, VD-210-40-2B	90	120		131,5	129	125,5	121	115,5	110	103,5	94
VF, VX, VN, VD-210-40-2A	110	150		138,5	136	132	128	124	118	111	102,5
VF, VX, VN, VD-210-40-A	110	150		148	145,5	142,5	138	134	128	122	113
VF, VX, VN, VD-210-40	110	150		157,5	155,5	152,5	148	143,5	138	132,5	123,5

Curva de rendimiento ISO9906:2012 Grado 3B

